



# Leadshine

## Hardware Manual of the Easy Servo Drives *ES-DH Series*



Version 1.3

<http://www.Leadshine.com>

---

## Safety Items

---



Read this manual carefully before trying to install the stepper drive into your system. The people who setup the stepper drive should have a better understanding on electronics and mechanics. Contact Leadshine technical guys when you have questions on this document

---



Make sure the power supply voltage dose not exceed the drive's input range. Double check the connections and make sure the power lead polarity is correct.

---



Do not set high current for small stepper motor. It is possible that the motor will be damaged.

---



Disconnect the motor from the load if you are not sure the move direction. Adjust the axis in the center before trying to run the motor.

---



Never disconnect the motor lead when the power source is energized.

## Table of Contents

<i>Introduction to Easy Servo</i> .....	1
<i>Getting Start</i> .....	1
<i>Wiring Diagrams</i> .....	2
<i>Connecting Power Supply</i> .....	3
<i>ES-DH1208</i> .....	3
<i>ES-DH2306</i> .....	3
<i>Connecting Motor</i> .....	4
<i>ES-DH1208 and the ES-MH2 Series Motor</i> .....	4
<i>ES-DH2306 and the ES-MH3 Series Motor</i> .....	4
<i>Connecting Encoder</i> .....	5
<i>Connecting Control Signal</i> .....	6
<i>Pulse, Direction, Enable Input</i> .....	6
<i>Alarm Output</i> .....	7
<i>Connecting PC</i> .....	8
<i>Typical Connections</i> .....	9
<i>Wiring Notes</i> .....	10
<i>Configuration</i> .....	10
<i>Configuring an ES drive by the on-board HMI</i> .....	11
<i>Display Data Mode</i> .....	12
<i>Edit Parameter Mode</i> .....	13
<i>Configuration Example via the on-board HMI</i> .....	15
<i>Calculating Rotation Speed and Angle</i> .....	16
<i>Rotating the Motor via the On-board HMI</i> .....	16
<i>Rotating the Motor by Motion Controller</i> .....	17
<i>Rotating the ES Motor in PC Software</i> .....	17
<i>Power Supply Selection</i> .....	18
<i>Multiple Drives</i> .....	18
<i>Selecting Supply Voltage</i> .....	18
<i>Recommended Supply Voltage</i> .....	19
<i>Control Signal Setup Timing</i> .....	19
<i>Current Control Detail</i> .....	20
<i>Fine Tuning</i> .....	20
<i>Protection Functions</i> .....	20
<i>Over-current Protection</i> .....	21
<i>Over-voltage Protection</i> .....	21
<i>Position Following Error Protection</i> .....	21
<i>Frequently Asked Questions</i> .....	22
<i>Problem Symptoms and Possible Causes</i> .....	22
<i>Warranty</i> .....	23
<i>Exclusions</i> .....	23

---

<i>Obtaining Warranty Service</i> .....	23
<i>Warranty Limitations</i> .....	23
<i>Shipping Failed Product</i> .....	23
<i>Contact Us</i> .....	24

## *Introduction to Easy Servo*

The ES (Easy Servo) series easy servos offer an alternative for applications requiring high performance and high reliability when the traditional servo was the only choice, while it remains cost-effective. The system includes an easy servo motor combined with a fully digital, high performance easy servo drive. The internal encoder is used to close the position, velocity and current loops in real time, just like servo systems. It combines the best of servo and stepper motor technologies, and delivers unique capabilities and enhancements over both, while at a fraction of the cost of a servo system.

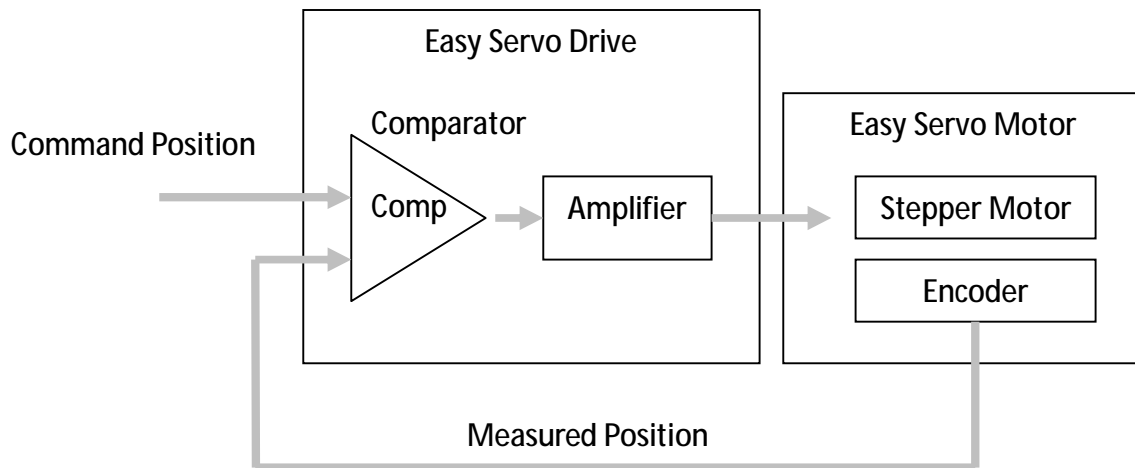

## *Getting Start*

To get start you need one easy servo drive, one easy servo motor (stepper drive with encoder) and an AC / DC power supply for the first time evaluation. A motion controller - like indexer, pulse generator or PLC is required too if you would like to verify the complete function. If you have a PC with one serial port or one PC with USB-RS232 converter, you can also rotate the motor in the PC software. However it is recommended to verify the complete function of the easy servo using another motion controller.

## Wiring Diagrams

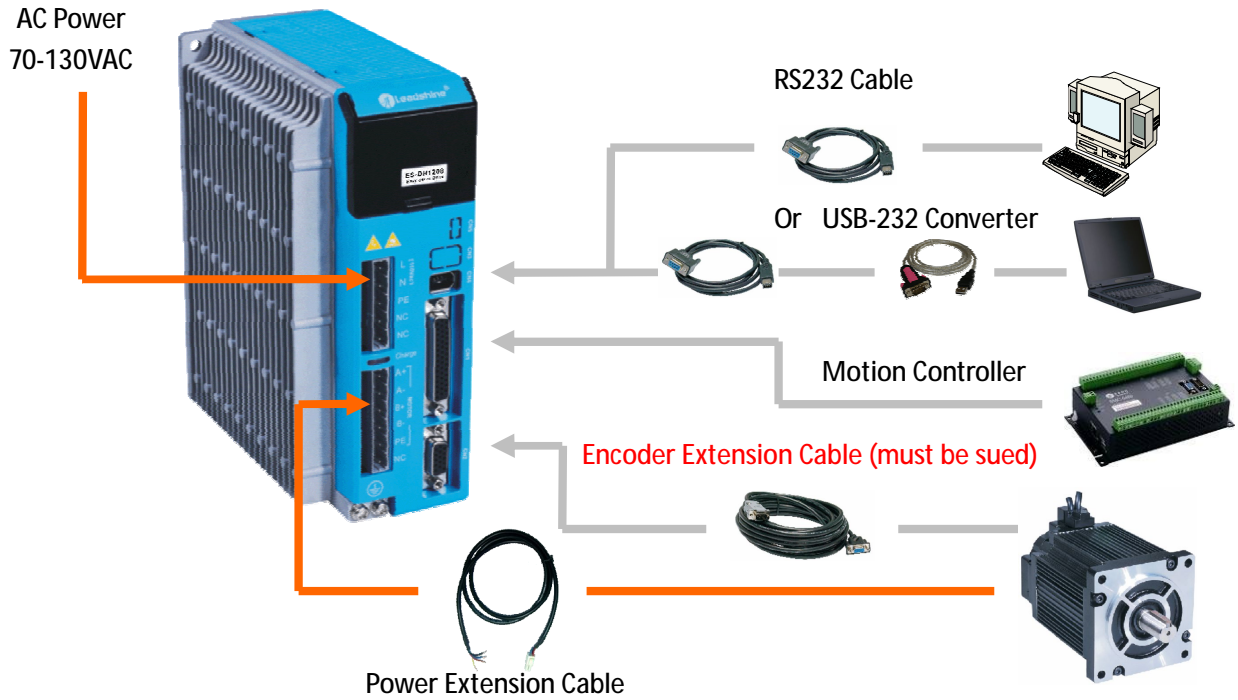

Wiring Diagram of the ES-DH1208 and ES-MH2 series motor

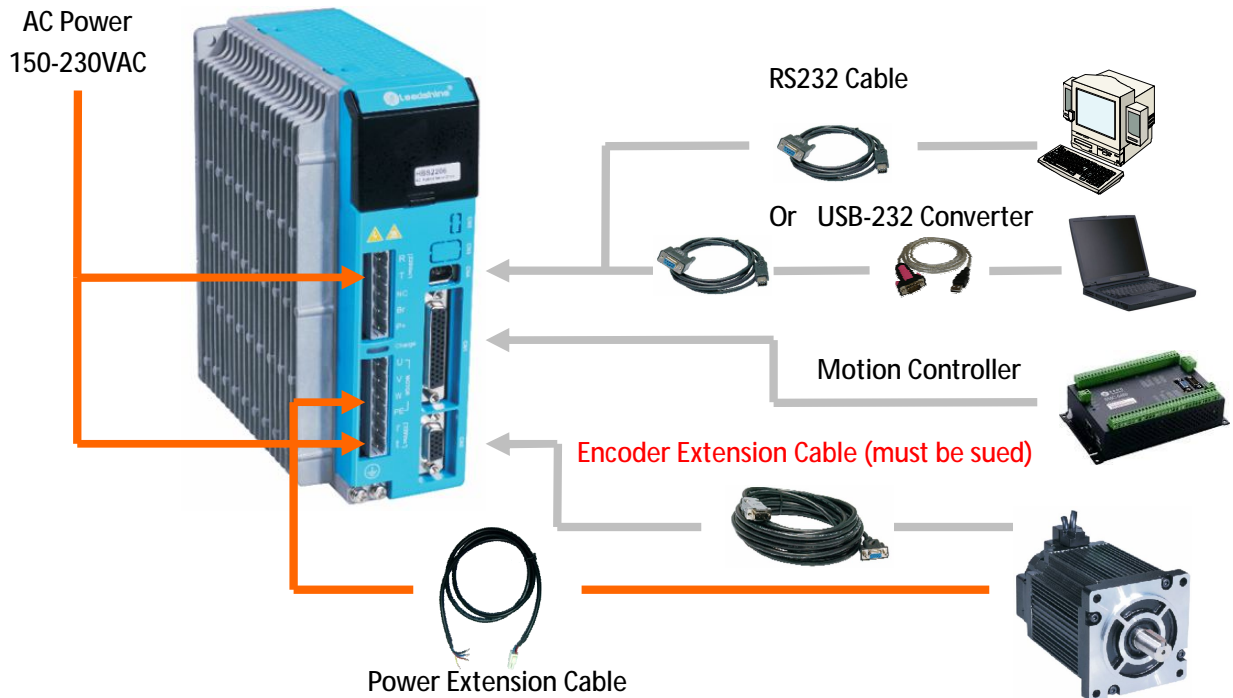

Wiring Diagram of the ES-DH2306 and ES-MH3 series motor

## Connecting Power Supply

### ES-DH1208

The power of the ES-DH1208 can be connected as follows.

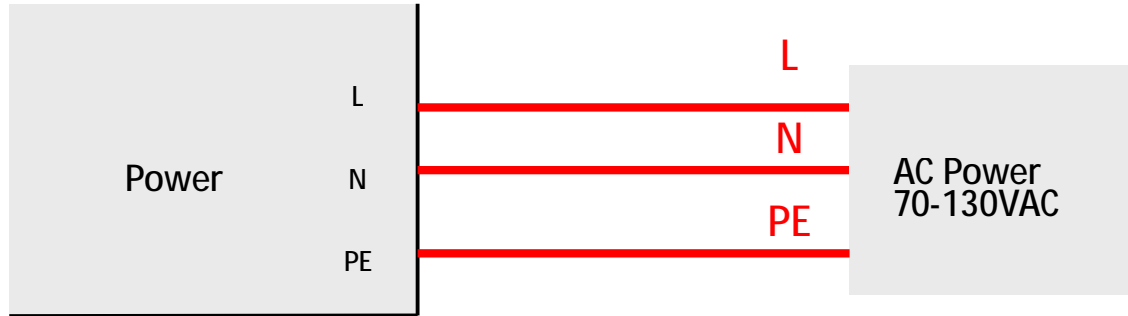

AC Power connections of the ES-DH1208

### ES-DH2306

The ES-DH2306 requires two powers input as follows. The main power is used to energize the motor and the control power is used for logic circuit. Typically they can share the same AC power.

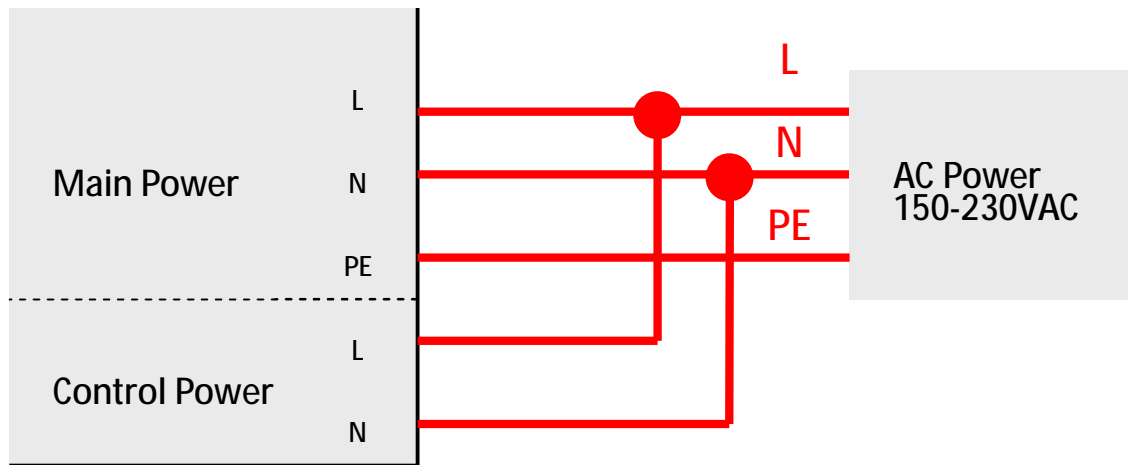

AC Power connections of the ES-DH2306

## Connecting Motor

### ES-DH1208 and the ES-MH2 Series Motor

A power extension cable is required to connect the ES-MH2 series motors and the ES-DH1208. One end of this power extension cable includes four flying wires. You can connect these wires to the drive's corresponding terminals as follows.

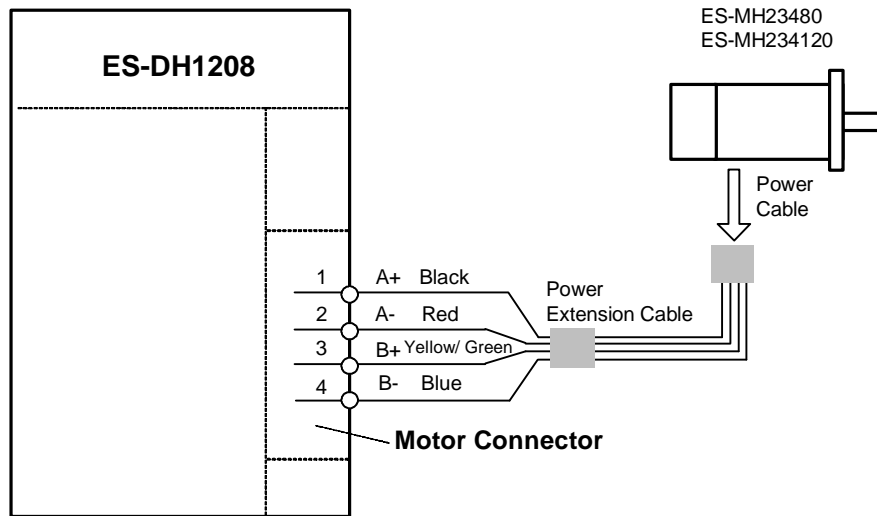

Connect Leadshine ES-MH2 series motors to the ES-DH1208

### ES-DH2306 and the ES-MH3 Series Motor

A power extension cable is required to connect the ES-MH3 series motors and the ES-DH2306. One end of this power extension cable includes four flying wires. You can connect these wires to the drive's corresponding terminals as follows.

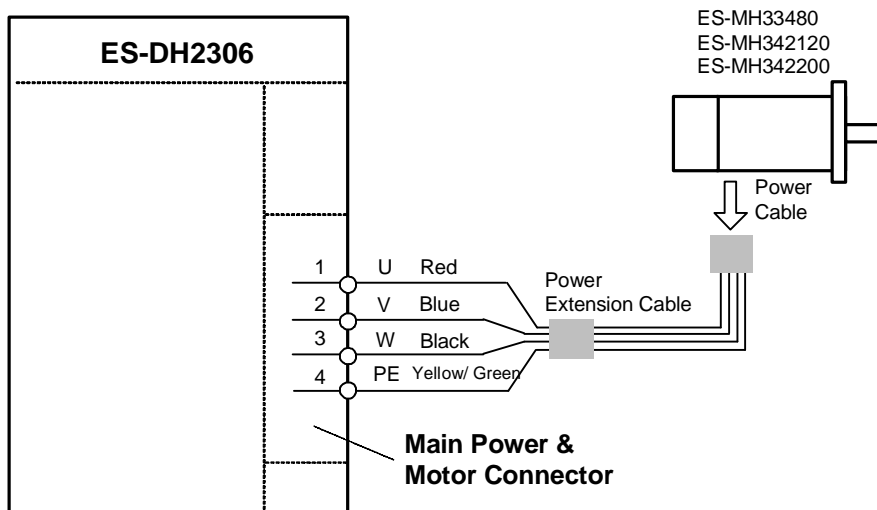

Connect Leadshine ES-MH3 series motors to the ES-DH2306



## Connecting Encoder

As the easy servo drive works in close-loop mode, it needs to know the actual motor position. The encoder mounted in the motor offers such information. Note that the easy servo drive can not work without encoder feedback. The encoder output of the ES-MH motor is a HDD15 male connector. And the feedback input of the ES-DH drive is a HDD15 female connector. However, you can NOT connect them directly as their pin-out are not matched to each other. An encoder extension cable must be connected between the drive and motor.

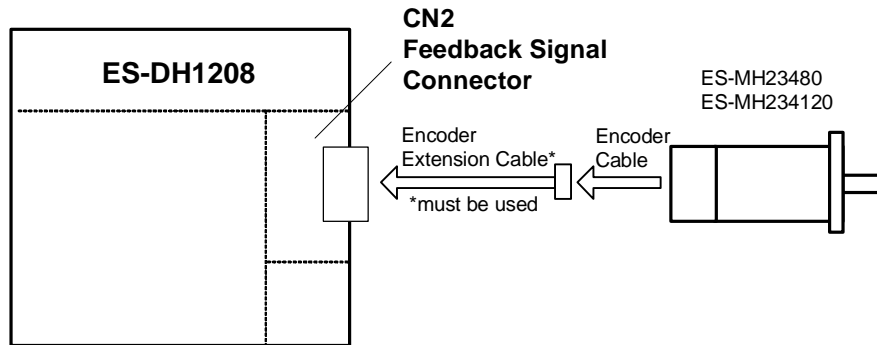

Encoder connections between ES-DH1208 drive and ES-MH2 motor

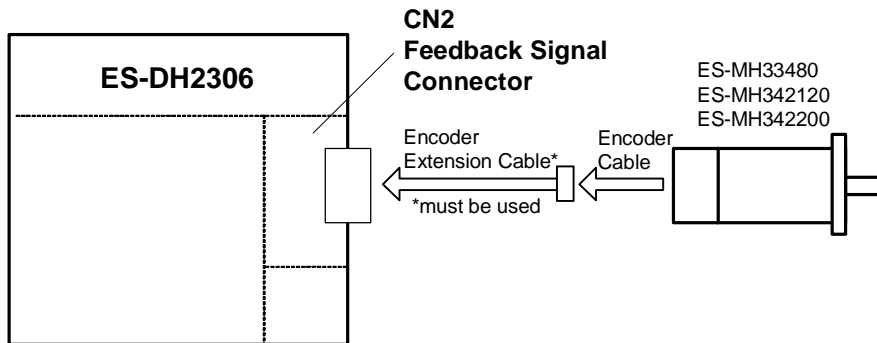

Encoder connections between the ES-DH2306 and ES-MH3 motors

## Connecting Control Signal

### Pulse, Direction, Enable Input

The ES-DH series drives can accept/receive differential pulse, direction and enable inputs. They can also be connected to PNP (sourcing) or NPN (sinking) type controllers. For the enable signal, apply 0V between ENA+ and ENA- or leave them unconnected to enable the drive. If you don't need to disable the drive, just leave them unconnected.

In a NPN (sinking) type output, the control signals share the same positive terminal.

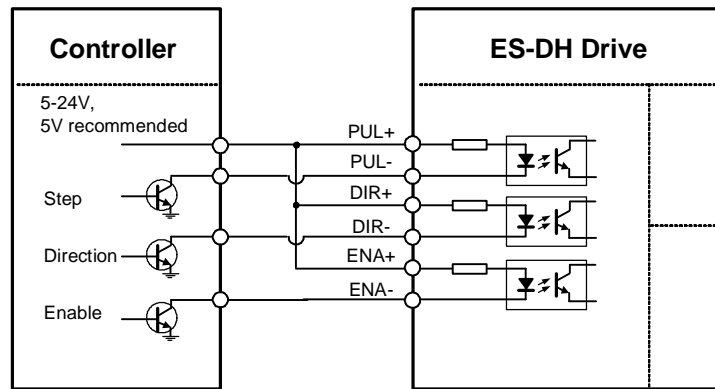

Connect the ES-DH drives to the NPN (sinking) type controllers

In a PNP (sinking) type output, the control signals are refer to the same ground terminal.

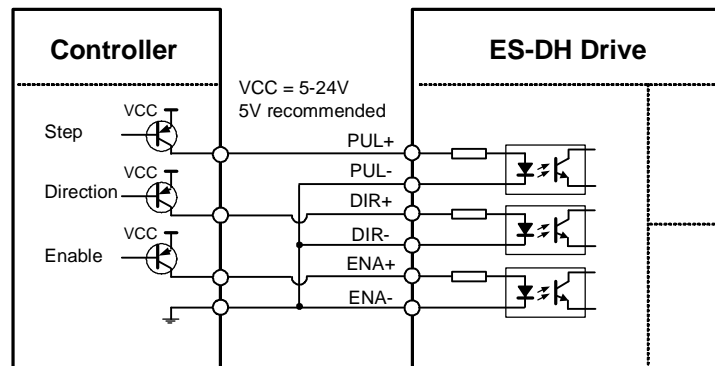

Connect ES-DH drives to the PNP (sinking) type controllers

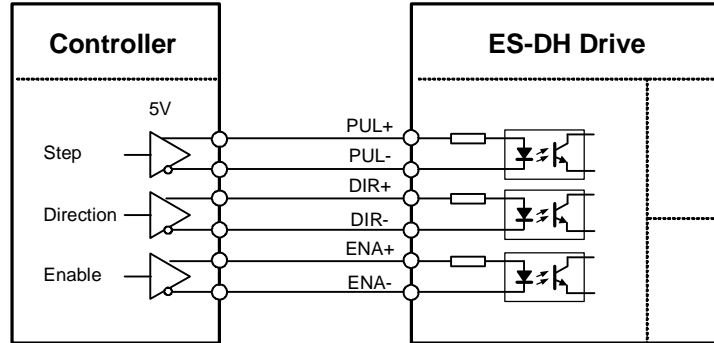
**Pulse, Direction, Enable Input (Continued)**

Connect ES-DH drives to the differential type controller

**Alarm Output**

The outputs is isolated and you can take it as an electronic switch. A upper resistor should be used to limit the current. Its resistance is depending on the input current requirement of the controller. The source voltage for those outputs can also be 24V. The resistor R is depending on the input current of the controller.

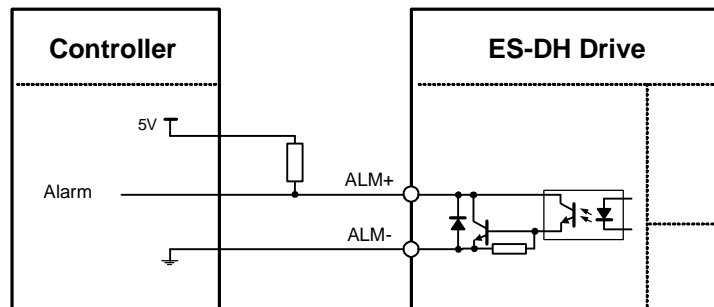

Alarm signal connection of the ES-DH drive

## Connecting PC

There is a built-in RS232 port in each easy servo drive for communication and configuration. Connect this port to the PC's serial port. Then you can rotate the motor in the setup software. This setup software - ProTuner, is designed to configure the easy servo drive. You can define the control mode, microstep resolution, current rate, active level of inputs/outputs in ProTuner.

The ProTuner can be downloaded from our website: <http://www.leadshine.com> or you may also get it from our CD. It is recommended to get it from the website because software from the website is always the latest. Install it in your PC and make it ready for use later.

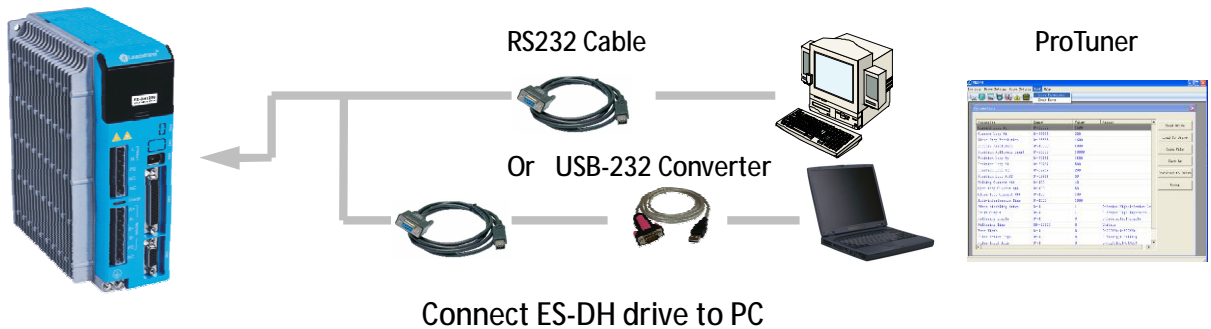

A RS232 cable is needed for the communication between the drives and the ProTuner. It will be shipped with the kit if you include it in the order. It is also possible to make this cable by yourself. One end of this cable is a 6-pin fire-wire header and the other end of cable is a 9 pin D-Sub female connector. If your PC does not have a serial port, a USB-to-232 converter is required.

**Note:** The power should be turned off when you perform any connections!

When you open ProTuner, a "Connect to drive" window appears. The "Baud Rate" and "Device Address" are fixed. You only need to select the "Com Port" according to the actual serial port or the mapping port of a USB-232 converter. Check the Device Manager for the mapping port number of the USB-232 converter.

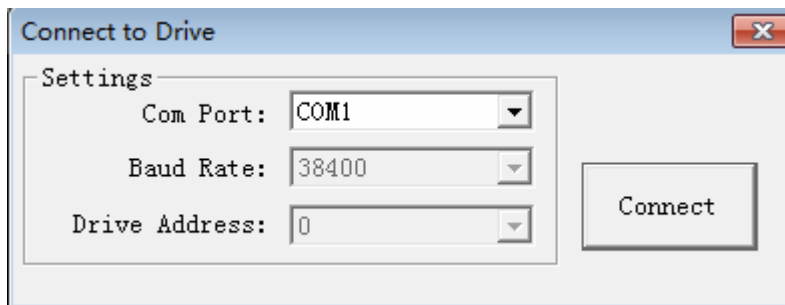

## Typical Connections

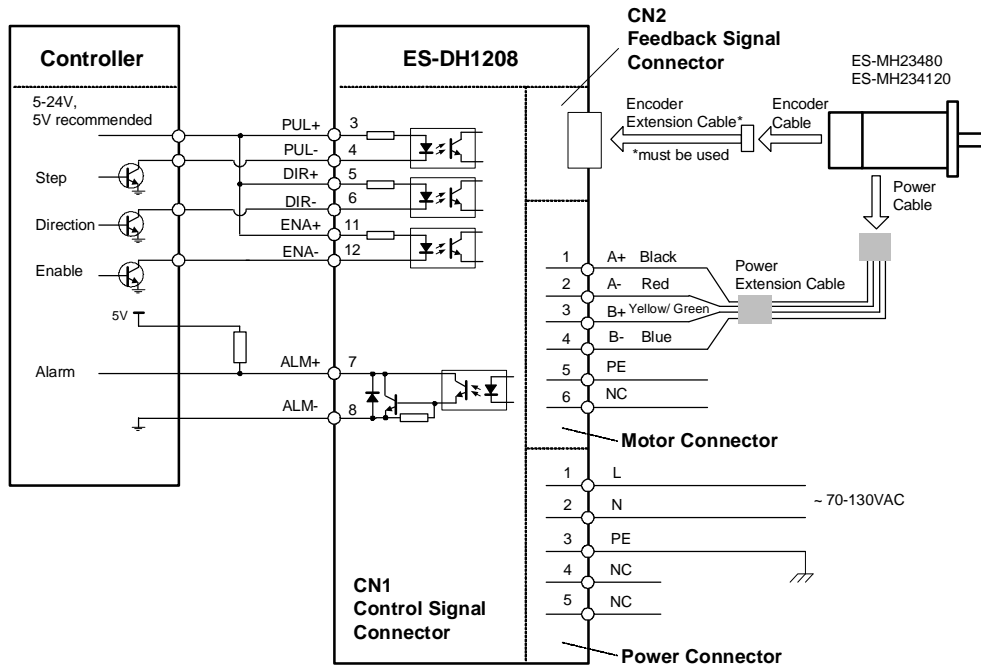

Typical Connections of ES-DH1208 with controller of sinking output

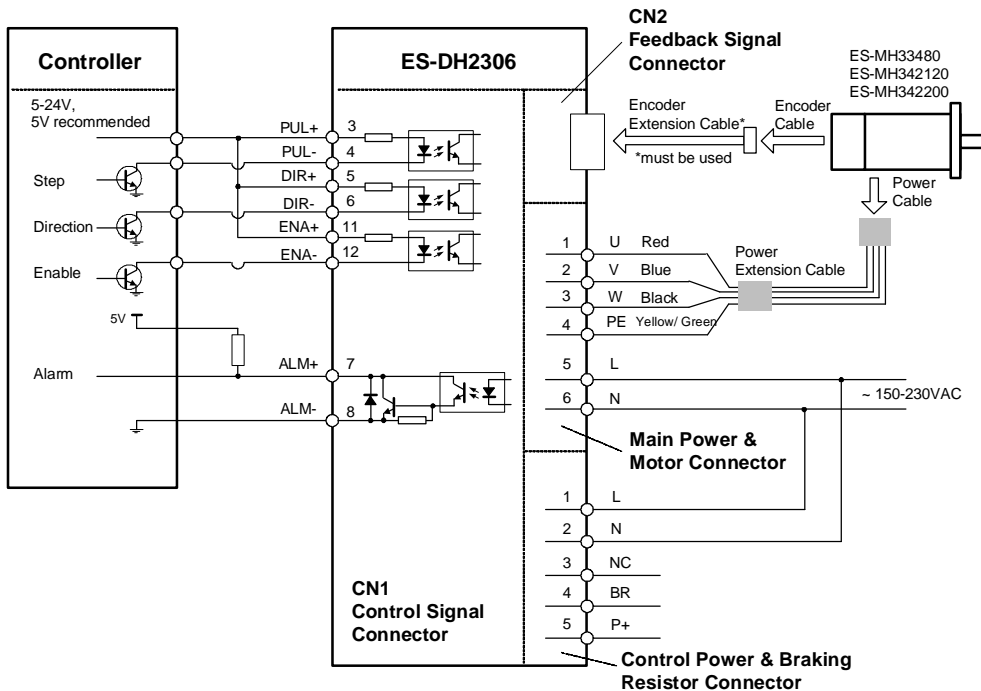

Typical Connections of the ES-DH2306 with controller of sinking outputs

## Wiring Notes

- I In order to improve anti-interference performance of the drive, it is recommended to use twisted pair shield cable.
- I To prevent noise incurred in PUL/DIR signal, pulse/direction signal wires and motor wires should not be tied up together. It is better to separate them by at least 10 cm, otherwise the disturbing signals generated by motor will easily disturb pulse direction signals, causing motor position error, system instability and other failures.
- I If a power supply serves several drives, separately connecting the drives is recommended instead of daisy-chaining.
- I It is prohibited to pull and plug power connector while the drive is powered ON, because there is high current flowing through motor coils (even when motor is at standstill). Pulling or plugging power connector with power on will cause extremely high back-EMF voltage surge, which may damage the drive.

## Configuration

When the default settings of the easy servo drives are not suitable for your application, it is necessary to configure it via the on board HMI or the configuration software ProTuner. Otherwise you may encounter problems like high motor heating, big motor noise or even motor stall due to weak torque. For a quick start of the easy servo drive, there are not much parameters need to be configured. The following table gives the most significant settings of the easy servo drives.

Most significant settings of the easy servo drive











Parameters	ES-DH1208	ES-DH2306
Pulses/Revolution	Default 4000, Software Adjustable	Default 4000, Software Adjustable
Holding Current (%)	Default 40%, Software Adjustable	Default 40%, Software Adjustable
Close-loop Current Limit (%)	Default 60% , Software Adjustable	Default 60% , Software Adjustable
Current Loop Kp	<i>*Auto Tuning at Power-up</i>	<i>*Auto Tuning at Power-up</i>
Current Loop Ki	<i>*Auto Tuning at Power-up</i>	<i>*Auto Tuning at Power-up</i>

*\*Auto Tuning at Power-up: It is possible to disable this feature in the setup software in order to tune the current loop Kp and current loop Ki manually if the auto tuning result is not good enough. This happens when the motor's inductance or resistance is too high or too low.*

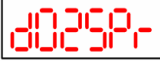

### Display Data Mode

This mode is active initially at drive's power-up. In this mode, users can check the monitoring data as shown in the following table.

Display Code	Name	Description
	"L "	Low order digits display.
	"H "	High order digits display.
	"d00uEP"	Position error which is the difference between command and feedback. Press "◀" to switch between low and high order digits display.
	"d01SPF"	Actual feedback motor speed in RPM.
	"d02SPr"	Reference motor speed in RPM.
	"d03PLF"	Actual feedback position in pulses.
	"d04PLr"	Reference position in pulses.
	"d05iP "	Reference current (peak) in mA.
	"d06Err"	Error code: 0001----Over-current protection activated 0002----Over-voltage protection activated 0008----Brake protection activated 0020----Position error exceeds the limit
	"d07 Pn"	Bus voltage which is 1/10 of the actual value.
	"d08 no"	Drive version number.



### Edit Parameter Mode

In this mode, the parameter is identified by the code “PA\_\_XX” as shown in the following table.

Display Code	Name	Default Value	Range	Description
“PA__00”	Current Loop Kp	1000	0-65535	Proportional gain. Increase it make current rise faster. Too large value may leads to big vibration and noise or even unstable.
“PA__01”	Current Loop Ki	200	0-65535	Integral gain, eliminating the steady error of the current loop. Too big may cause vibration, noise or even unstable.
“PA__02”	Current Loop Kc	256	0-1024	High value reduces mid-speed vibration but the motor current also drops fast.
“PA__03”	Position Loop Kp	2500	0-65535	Position loop proportional gain.
“PA__04”	Position Loop Ki	500	0-65535	Eliminates the steady error of the position loop when the motor is standstill.
“PA__05”	Position Loop Kd	200	0-1000	Reduces over shoot of the position.
“PA__06”	Position Loop Kvff	30	0-100	Compensate the motor and control loop delay.
“PA__07”	Pulses/Revolution	4000	200-65535	Set the pulses count to make the motor rotate one revolution.
“PA__08”	Encoder Resolution	4000	200-65535	X4 quadrature decoding, default value is for 1000 lines encoder.
“PA__09”	Position Error Limit	1000	1-65535	When the position error exceeds this value, the drive goes into error state. Unit: Pulses
“PA__10”	Holding Current Rate	40%	0-100	It affects the holding torque when the motor is at standstill. It also determines the start current when the motor starts to work again. The actual current is the drive’s MAX current multiplied by the holding current rate. For example, the drive’s MAX current is 6A. So the default actual holding current is $6 \times 40\% = 2.4A$ . Large value will offer better acceleration performance while causes more heating.
“PA__11”	Close-loop Current Rate	100%	1-100	This parameter limits the MAX dynamic torque when the motor is in motion. The actual current limit is the drive’s MAX current multiplied by the close-loop current rate. Large value will offer better acceleration performance while causes more heating.

"PA__12"	Standby Time	1000ms	1-65535	This parameter defines the waiting time for the drive entering into standby mode when there is no pulse input to the drive. In standby mode, small position error will be ignored.
"PA__13"	Pulse Filter	0	0 or 1	0----Disable Pulse Filter 1----Enable Pulse Filter
"PA__14"	Filter Time	25600us	0-25600	The higher value the smoother motion. But higher value also leads to high delay.
"PA__15"	Enable Level	1	0 or 1	0----Users must apply a 5V between ENA+ and ENA- to enable the drive. 1----The drive is enable when voltage drop between ENA+ and ENA- is 0V or left unconnected.
"PA__16"	Alarm Level	1	0 or 1	0----High impedance between ALM+ and ALM- at drive error 1----Low impedance between ALM+ and ALM- at drive error
"PA__17"	Pulse Mode	0	0 or 1	0----Pulse + Direction 1----Pulse + Pulse (CW/CCW)
"PA__18"	Pulse Edge	0	0 or 1	0----Active Rising Edge 1----Active Falling Edge
"PA__19"	Motor Direction	1	0 or 1	0 and 1 represents two different directions (CW / CCW).
"PA__20"	Pulse Bandwidth	0	0 or 1	0----The MAX pulse frequency is limited to 200KHz 1---- The MAX pulse frequency is limited to 500KHz
"PA__21"	Acceleration	200	1-2000	Acceleration of the built-in motion controller. Unit: Revolutions / second
"PA__22"	Speed	60 RPM	1-3000	Speed of the built-in motion generator. Unit RPM
"PA__23"	Move Distance	100 rev.	1-65535	Move distance of the built-in motion controller. The actual distance is 1/100 of the setting value. Unit: Revolutions
"PA__24"	Repeat Times	1	1-65535	Repeat times of the built-in motion controller.
"PA__25"	Initial Direction	1	0 or 1	0 and 1 represents two different directions of the motion commands.
"PA__26"	Dwell	100ms	1-65535	Waiting time to the next trapezoid velocity motion when one motion completes. Unit: ms

"PA__27"	Motion Type	1	0 or 1	0----One direction motion 1----Positive and negative motion
"PA__28"	Motion Start/Stop	0	0 or 1	1----Start Motion 0----Stop Motion The motion starts when applying "1" to this parameter. It backs to "0" when the motion completes.
"PA__29"	Reserved	-	-	-

### Configuration Example via the on-board HMI

The following figure illustrates how to set the "Standby Time" via the on-board HMI. Looking up the table in the "Edit Parameter Mode" section, this parameter refers to "PA\_\_12" item. So the setting procedure is shown as follows:

#### Power-Up

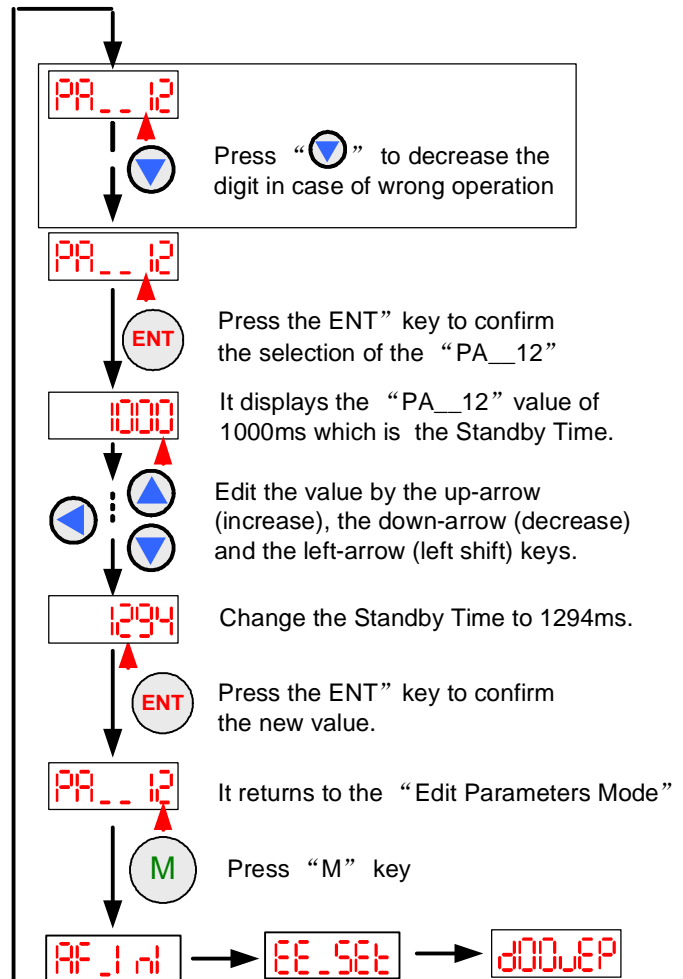
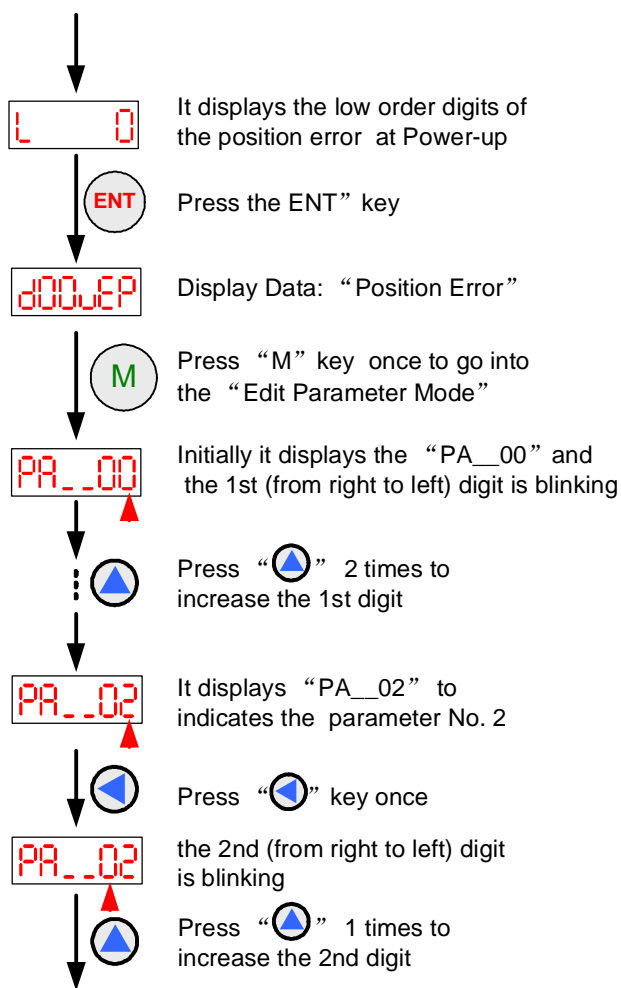

## Calculating Rotation Speed and Angle

You may also want to calculate the motor rotation speed and rotation angle, before commanding any motion. If the pulse frequency and counts are known, they can be calculated as follows:

$$\text{Rotation Speed (RPM)} = 60 * \text{Pulse (Step) Frequency} / (\text{Pulses/Revolution})$$

$$\text{Rotation Angle (}^\circ\text{)} = 360 * \text{Pulse (Step) Counts} / (\text{Pulses/Revolution})$$

## Rotating the Motor via the On-board HMI

User's can rotate the motor by the on-board HMI for test purpose. A motion generator has been built inside the drive. To start the motion, first you need to setup the motion parameter such as motion velocity, motion distance, acceleration and initial direction, etc. The detailed steps are shown in the following picture.

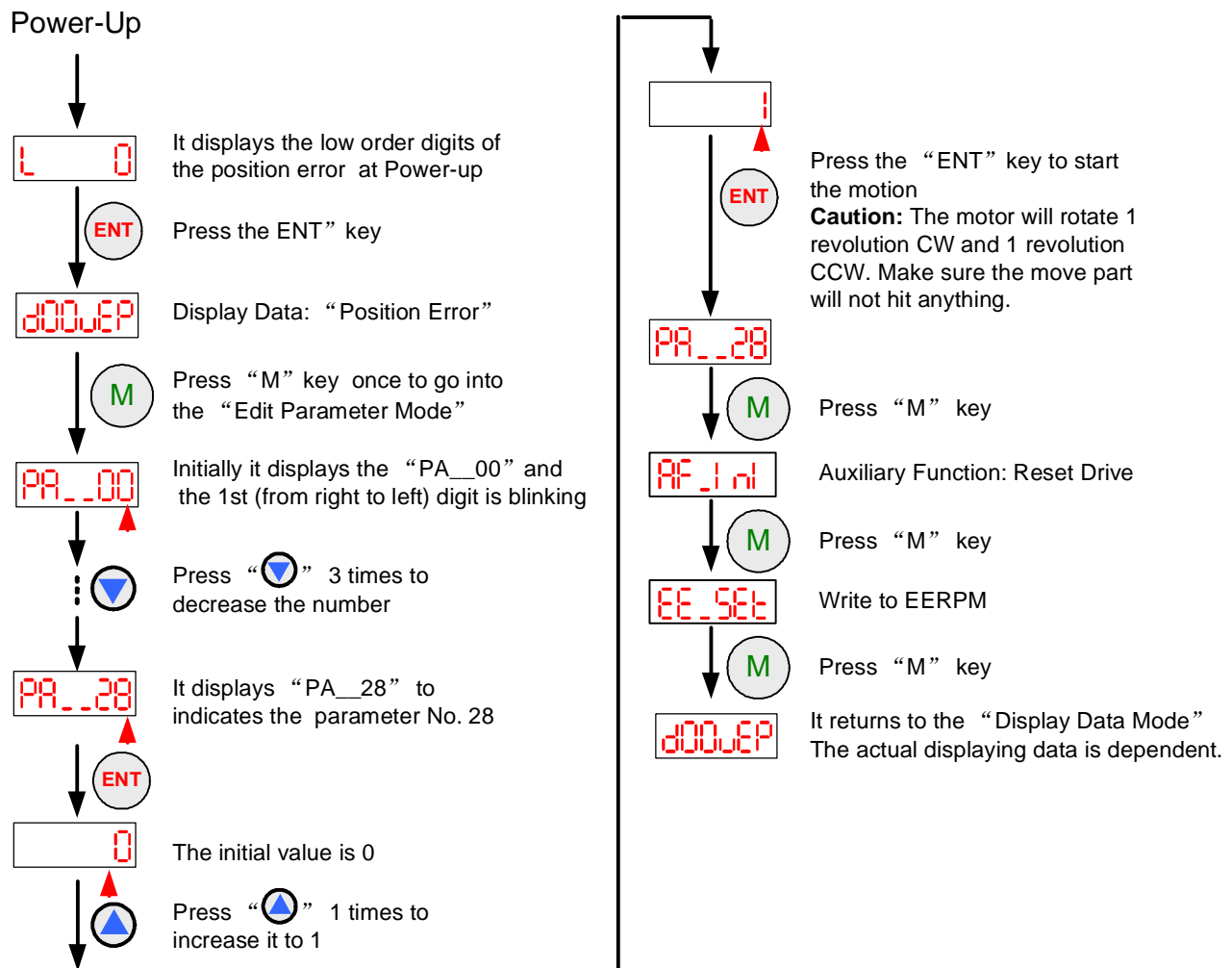

## Rotating the Motor by Motion Controller

You can start the controller or pulse generator to rotate the motor. Actually, any device which gives high-to-low or low-to-high level changes can be used to move the motor. If it is your first time installation, it is recommended to disconnect the motor shaft from the load in case of accident. You can start from low pulse frequency then going to high. One triggered edge of the pulse makes the motor move one micro angle. The maximum running speed will be determined by the input voltage and current setting. The minimum speed is limited by “Standby Time”, see more information in page 13 regarding “Standby Timer”.

## Rotating the ES Motor in PC Software

There is a simple emulating controller that is used for self-test in the ES drive. It is not a full functionality controller but it does eliminate the troubles to setup a real motion controller when you want to test the ES drives or verify the connections. However, the performance using the emulating controller and the PC software CAN NOT represent the performance using the actual motion controller.

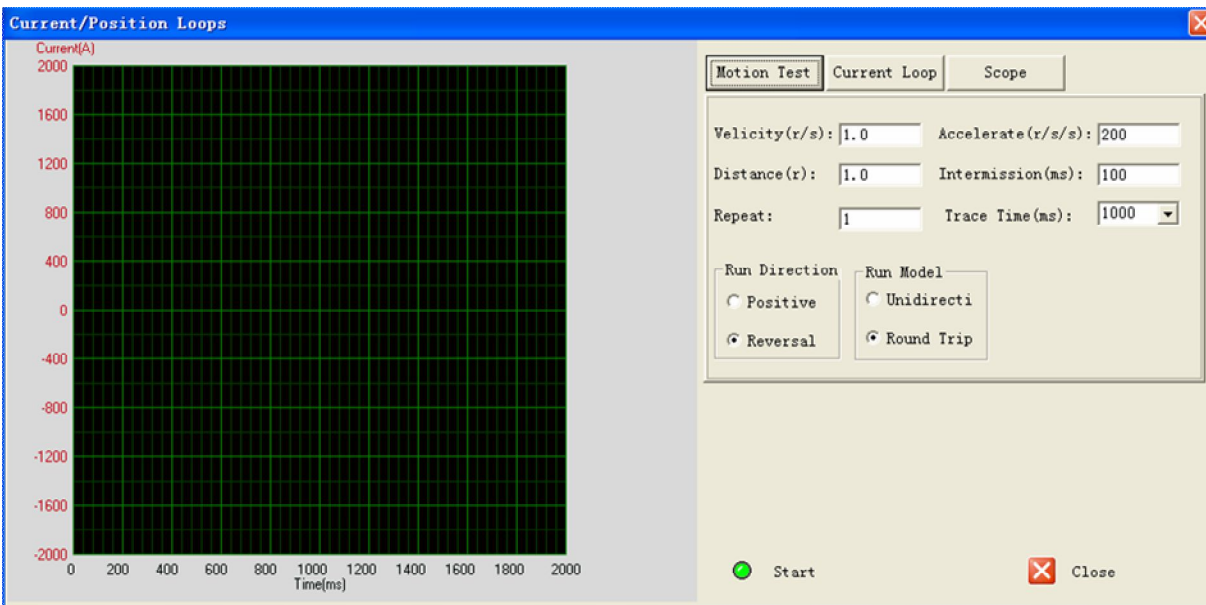

Click Drive Setting->Current Loop / Motion Test to open the test window. Then click the Motion Test tab to open the emulating controller. Edit the trapezoid velocity profile and click the Start button to issue the motion.

## Power Supply Selection

To achieve good driving performances, it is important to choose a suitable supply voltage and use a matching current value. Generally speaking, supply voltage determines the high speed performance of the motor, while output current determines the output torque of the driven motor (particularly at lower speed). Higher supply voltage will allow higher motor speed to be achieved, at the price of more noise and heating. If the motion speed requirement is low, it's better to use lower supply voltage to decrease noise, heating and improve reliability.

### Multiple Drives

It is recommended to have multiple drives to share one power supply to reduce cost, if the supply has enough capacity. To avoid cross interference, DO NOT daisy-chain the power supply input pins of the drives. Instead, please connect them to power supply separately.

### Selecting Supply Voltage

Higher supply voltage can increase motor torque at higher speeds, thus helpful for avoiding losing steps. However, higher voltage may cause bigger motor vibration at lower speed, and it may also cause over-voltage protection or even drive damage. Therefore, it is suggested to choose only sufficiently high supply voltage for intended applications, and it is suggested to use power supplies with theoretical output voltage of drive's minimum + 10% to drive's maximum – 10%, leaving room for power fluctuation and back-EMF.

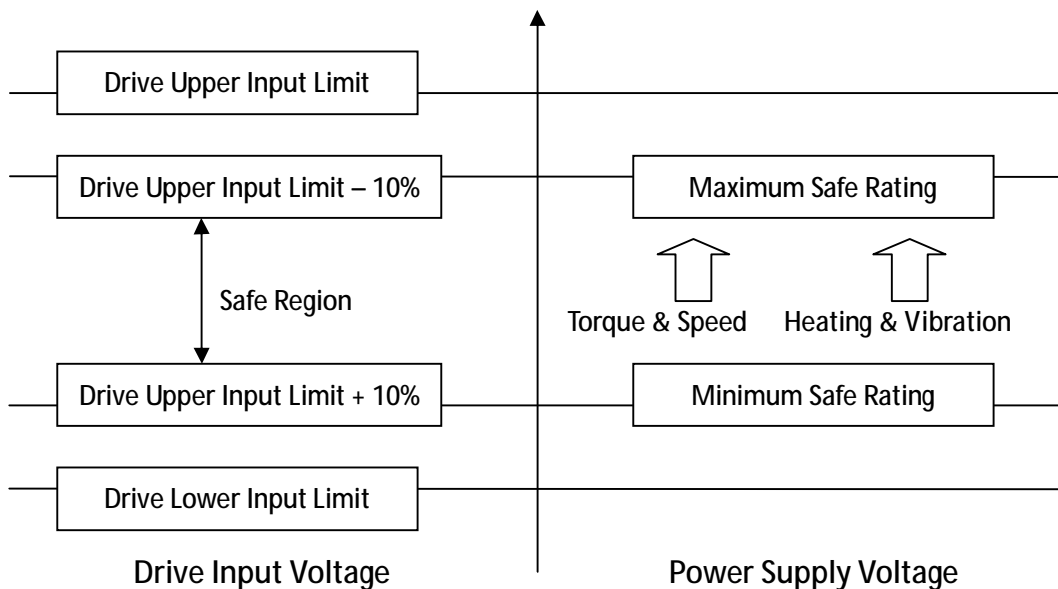

## Recommended Supply Voltage

Motor	Drive	Voltage Range	Typical Voltage
ES-MH23480	ES-DH1208	AC(70-130)V	AC 110/120V
ES-MH234120	ES-DH1208	AC(70-130)V	AC 110/120V
ES-MH33480	ES-DH2306	AC(150-230)V	AC 220/230V
ES-MH342120	ES-DH2306	AC(150-230)V	AC 220/230V
ES-MH342200	ES-DH2306	AC(150-230)V	AC 220/230V

## Control Signal Setup Timing

To make a reliable operation, the ES drive requires the control signals to meet the setup time requirements as follows. Otherwise losing of steps may happen.

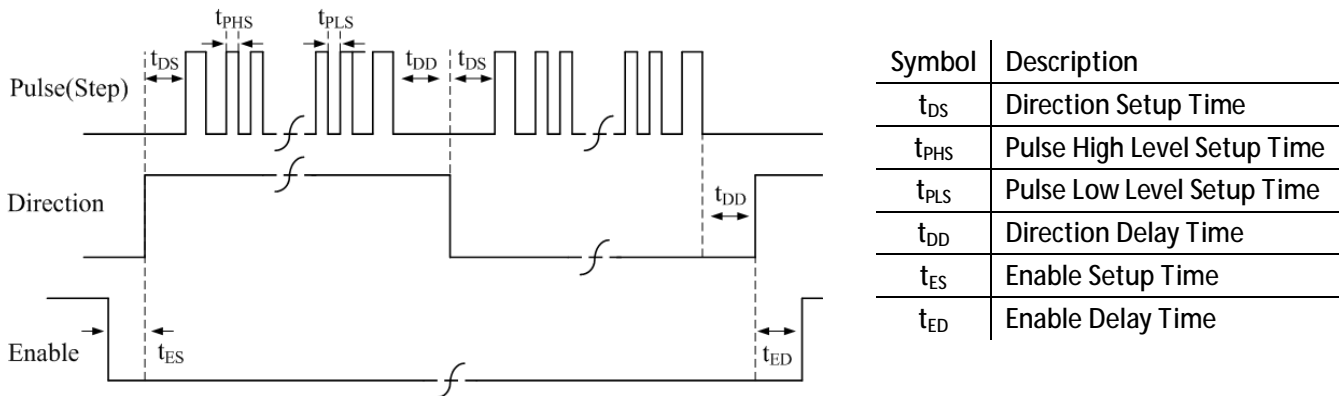

Control Signal Setup Time						
Drive	Frequency	$t_{DS}$	$t_{PHS} / t_{PLS}$	$t_{DD}$	$t_{ES}$	$t_{ED}$
ES-DH2306	200K	>5 $\mu$ S	>2.5 $\mu$ s	>5 $\mu$ S	>50ms	>50ms
ES-DH2306	500K	>5 $\mu$ S	>1.0 $\mu$ s	>5 $\mu$ S	>50ms	>50ms
ES-DH1208	200K	>5 $\mu$ S	>2.5 $\mu$ s	>5 $\mu$ S	>50ms	>50ms
ES-DH1208	5200K	>5 $\mu$ S	>1.0 $\mu$ s	>5 $\mu$ S	>50ms	>50ms

## Current Control Detail

Leadshine's easy servo motor is integrated with a high-resolution 1,000-line optical incremental encoder. That encoder can send the real-time shaft position back to the ES-DH drive. Like traditional servo controls, the drive can automatically adjust the output current to the motor. The output current ranges between the holding current and the close-loop current. When there is no pulse sent to the drive, the ES-DH drive goes into idle mode and the actual motor current is determined by the holding current percentage (similar to "idle current" of open loop stepper drives). In normal working mode, the ES-DH drive monitors the actual shaft position all the time. The current outputted to the motor changes dynamically based on the tracking error between the actual position and the commanded position.



Low holding current can reduce motor heating however also reduces the holding torque which is used to lock the motor shaft at standstill. It is recommended to determine the holding current by whether or not there is big vibration at start-up and how much lock torque is required, based on your actual applications.

## Fine Tuning

Leadshine already loads default current-loop parameters and position-loop parameters. Those default parameter values have been optimized. They should be good enough for most industrial applications, and there is no need to tune them. However, if you want to fine tune the IES for best performance for your applications, Leadshine also offers tuning software, ProTuner, which allows you to adjust those current-loop and position-loop parameters (see software manual).

## Protection Functions

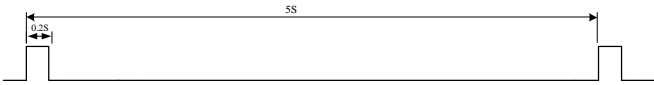
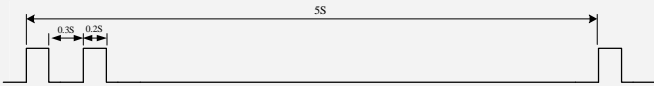
To improve reliability, the ES incorporates some built-in protection functions. The ES uses one red LED to indicate the protection type. The periodic time of red is 5 s (seconds), and the blinking times of red LED indicates what protection has been activated. Because only one protection can be displayed by red LED, so the drive will decide what error to display according to their priorities. See the following protection indications table for displaying priorities.

Priority	Time(s) of Blink	Sequence wave of RED LED	Description
1st	1		Over-current protection
2nd	2		Over-voltage protection
3rd	7		Position Following Error



### *Over-current Protection*

Over-current protection will be activated when continuous current exceeds the limit or in case of short circuit between motor coils or between motor coil and ground, and RED LED will blink once within each periodic time.

### *Over-voltage Protection*

When power supply voltage exceeds the limits, protection will be activated and red LED will blink twice within each periodic time.

---



When above protections are active, the motor shaft will be free and the LED will blink. Reset the drive by repowering it to make it function properly after removing above problems.

---

### *Position Following Error Protection*

When the position error exceeds its limit (software configurable, see software manual), position, protection will be activated and red LED will blink seven times within each periodic time.

## *Frequently Asked Questions*

In the event that your drive doesn't operate properly, the first step is to identify whether the problem is electrical or mechanical in nature. The next step is to isolate the system component that is causing the problem. As part of this process you may have to disconnect the individual components that make up your system and verify that they operate independently. It is important to document each step in the troubleshooting process. You may need this documentation to refer back to at a later date, and these details will greatly assist our Technical Support staff in determining the problem should you need assistance.

Many of the problems that affect motion control systems can be traced to electrical noise, controller software errors, or mistake in wiring.

## *Problem Symptoms and Possible Causes*

Symptoms	Possible Problems
Motor is not rotating	No power
	Encoder resolution setting is wrong
	Fault condition exists
	The drive is disabled
Motor rotates in the wrong direction	The direction signal level is reverse
The drive in fault	Power supply voltage beyond drive's input range
	Something wrong with motor coil
	Wrong connection
Erratic motor motion	Control signal is too weak
	Control signal is interfered
	Something wrong with motor coil
	Motor is undersized for the application
	Acceleration is set too high
	Power supply voltage too low
Excessive motor and drive heating	Inadequate heat sinking / cooling
	Load is too high

## *Warranty*

Leadshine Technology Co., Ltd. warrants its products against defects in materials and workmanship for a period of 12 months from shipment out of factory. During the warranty period, Leadshine will either, at its option, repair or replace products which proved to be defective.

## *Exclusions*

The above warranty does not extend to any product damaged by reasons of improper or inadequate handlings by customer, improper or inadequate customer wirings, unauthorized modification or misuse, or operation beyond the electrical specifications of the product and/or operation beyond environmental specifications for the product.

## *Obtaining Warranty Service*

To obtain warranty service, a returned material authorization number (RMA) must be obtained from customer service at e-mail: before returning product for service. Customer shall prepay shipping charges for products returned to Leadshine for warranty service, and Leadshine shall pay for return of products to customer.

## *Warranty Limitations*

Leadshine makes no other warranty, either expressed or implied, with respect to the product. Leadshine specifically disclaims the implied warranties of merchantability and fitness for a particular purpose. Some jurisdictions do not allow limitations on how long and implied warranty lasts, so the above limitation or exclusion may not apply to you. However, any implied warranty of merchantability or fitness is limited to the 12-month duration of this written warranty.

## *Shipping Failed Product*

If your product fail during the warranty period, e-mail customer service at to obtain a returned material authorization number (RMA) before returning product for service. Please include a written description of the problem along with contact name and address. Send failed product to distributor in your area or: ULeadshine Technology Co., Ltd. 3/F, Block 2, Nanyou Tianan Industrial Park, Nanshan Dist, Shenzhen, China.U Also enclose information regarding the circumstances prior to product failure.

## *Contact Us*

### China Headquarters

Address: 3/F, Block 2, Nanyou Tianan Industrial Park, Nanshan District Shenzhen, China

Web: <http://www.leadshine.com>

### Sales Hot Line:

Tel: 86-755-2641-7674 (for Asia, Australia, Africa areas)

86-755-2640-9254 (for Europe areas)

86-755-2641-7617 (for America areas)

Fax: 86-755-2640-2718

Email: [sales@leadshine.com](mailto:sales@leadshine.com).

### Technical Support:

Tel: 86-755-2641-8447, 86-755-2641-8774, 86-755-2641-0546

Fax: 86-755-2640-2718

Email: [tech@leadshine.com](mailto:tech@leadshine.com)(for All)

### Leadshine U.S.A

Address: 25 Mauchly, Suite 318 Irvine, California 92618

Tel: 1-949-608-7270

Fax: 1-949-608-7298

Web: <http://www.leadshineUSA.com>

Email: [sales@leadshineUSA.com](mailto:sales@leadshineUSA.com) and [support@leadshineUSA.com](mailto:support@leadshineUSA.com).