

Dimension: (Unit: mm)

版本 Rev.	日期 Date	变更文件号 ECN NO.	变更内容 Revisions	设计 By
V1.0	18.10.19		增加 Add Brake	王洪松

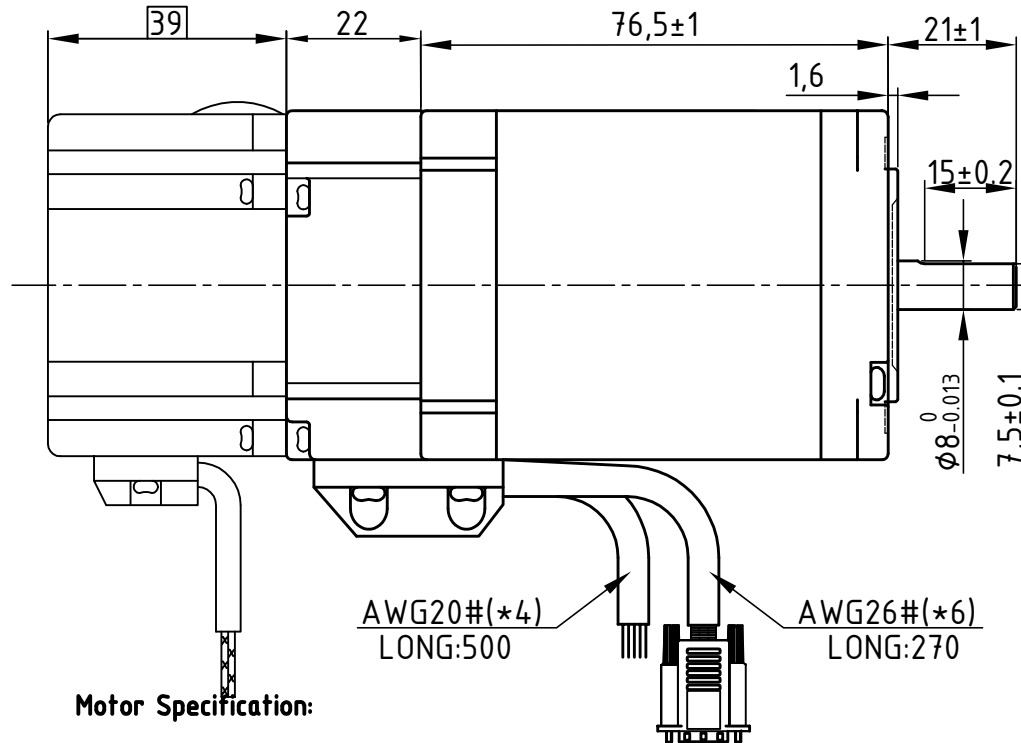

Motor Connctions:

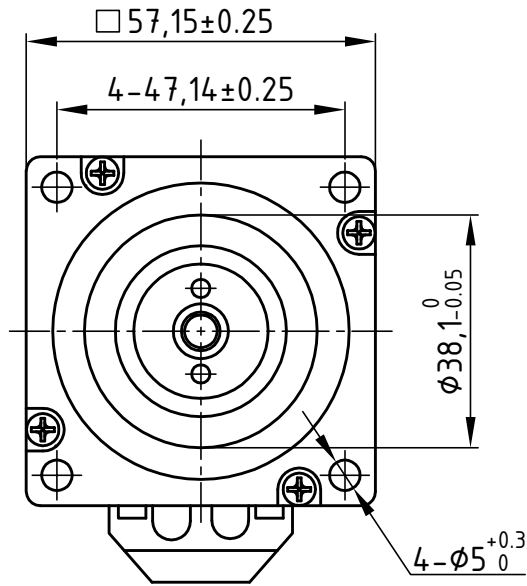
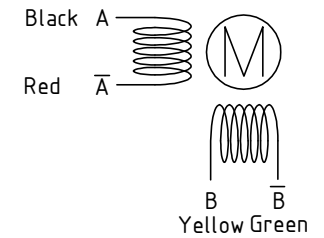

Encoder Signals

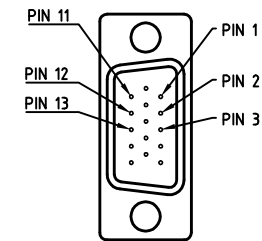

Common Rating

Step angle	1.8°
Position accuracy	1.8±0.09°
Dielectric strength	500VAC 1min
Insulation resistance	100MΩhm(500VDC)
Insulation class	B
Temp rise(Max)	80K
Radial play	Max.0.02mm(Load 450g)
Axial play	Max.0.08mm(Load 900g)

Motor Specification:

Current/phase	5 A
Voltage	2.0 V
DC Resistance/phase ±10%	0.4 Ω
Inductance/phase ±20%	1.7 mH
Holding torque	2.3 N·M
Inertia	0.5 kg·cm <sup>2</sup>
Weight	1.65 kg
Encoder Resolution	1000 cpr

AWG20#(\*4)  
LONG:500

AWG26#(\*6)  
LONG:270

PIN	1	2	3	11	12	13
Color	BLK	RED	WHT	YEL	GRN	BLU
Define	A+	VCC	GND	B+	B-	A-

Brake Connections

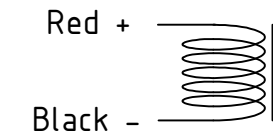

Brake Specification:

Voltage	24Vdc
Friction torque	2N·M

设计 Designed	王洪松	日期 Date	2017.10.30	材料 Material		LEADSHINE TECHNOLOGY CO., LTD.
审核 Checked	秦军	2017.10.30	第一角画法 First Angle projection		名称 Title	
批准 Approved	田天胜	2017.10.30	重量 Weight	比例 Scale	阶段标记 Stage Mark	CS-M22323B
料号 Part No.			共 1 页 第 1 页 Sheet 1 of 1	图号 DWG. NO.		LS-CM57-02-0111-03