

PIN	FUNCTION
1	MOTOR U YELLOW
2	MOTOR V RED
3	MOTOR W BLACK
4	MOTOR PE \leftrightarrow YELLOW/GREEN



Housing:H66L6-04P
Terminal:T66L6-A

Connector Detail (Power Wire)

PIN	FUNCTION	PIN	FUNCTION
1	DC +5V	9	W
2	GND	10	V
3	NC	11	/Z
4	U	12	/B
5	/U	13	/A
6	Z	14	/W
7	B	15	/N
8	A		

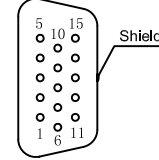

DB 15M

Connector Detail (Feedback Wire)

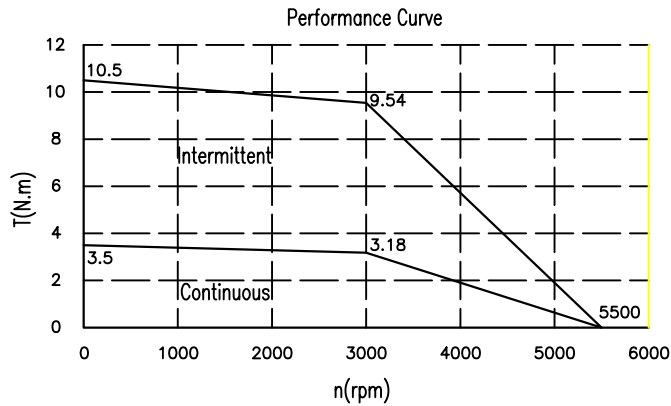
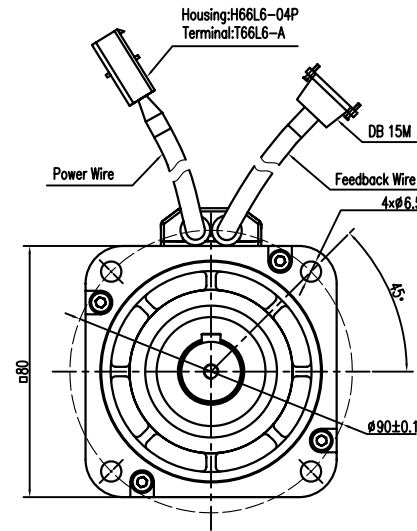
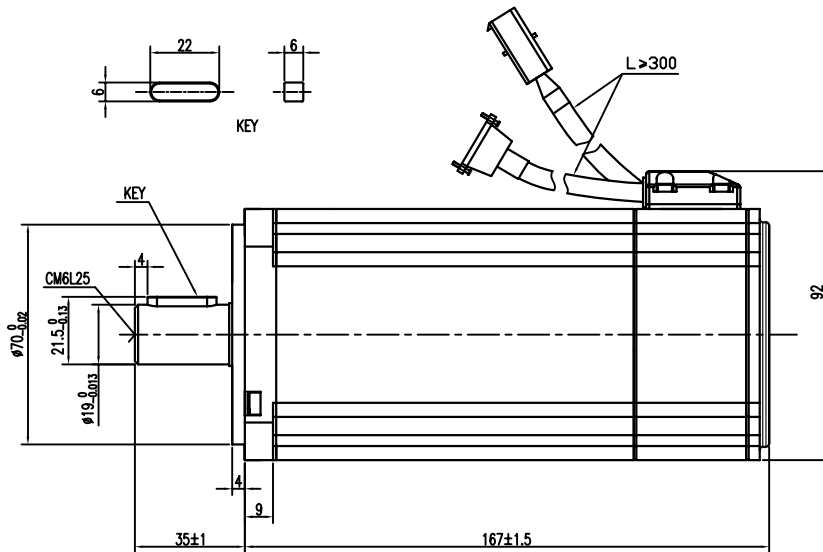

Kinco AC SERVO MOTOR
SMH80S-0100-30AAK-3LKH

W	1000	V	220
A	6.3	Nm	3.18
RPM	3000	Ins.	F

Kinco Electric (Shenzhen) Ltd. IP65
MADE IN CHINA
S/N: K3NHK00YYDDNNNN

CE

Technical Data		
No. of poles	6	
DC Link Voltage U_{dc} (DC Link)	300	
Rated Power P_n (W)	1000	
Rated Torque T_n (N.m)	3.18	
Rated Speed n_n (rpm)	3000	
Rated Current I_n (A)	6.3	
Maximum torque T_m (N.m)	9.54	
Maximum Current I_m (A)	18.9	
Standstill torque T_s (N.m)	3.5	
Standstill current I_s (A)	6.93	
Resistance line-line R_L (Ω)	0.86	
Inductance line-line L_L (mH)	4.5	
Electrical time constant τ_e (ms)	5.23	
Mechanical time constant τ_m (ms)	0.89	
Voltage constant K_v (V/krpm)	34	
Torque constant K_t (Nm/A)	0.562	
Rotor moment of inertia J_m (Kg.cm ²)	1.9	
Max. voltage rising du/dt (KV/ μ s)	8	
Insulation class	F	
Max. radial force F_r (N)	335	
Max. axial force F_a (N)	167.5	
Weight(Kg)	3.9	
Feedback device	2500p/rev incremental encoder OIH35-TSS214N310	
Temperature sensor	n.a.	
Cooling method	Totally enclosed non-ventilated	
protection level	IP65,shaft sealing IP54	
Environmental conditions	Temperature	-20 \sim 40 \circ C
	Humidity	Below 90%RH (No dewing)
	Environment	Far away active gas,combustible gas,oil drop,ash.
Rating conditions	Installation altitude	UP TO 1000m:rated power, above 1000m:1.5% power decreasing per 100m,max.4000m
	Mounting	Aluminum flange 255x255x6mm
	Temperature	60K housing temperature ring at 40 \circ ambient

REV	ECN NO.	DRN	APP'D	DATE	DESIGN	DATE	P/N.
							K3.162.5049SS
UNLESS OTHERWISE SPECIFIED TOLERANCES					MATERIAL	CONTR.	TITLE
DECIMALS: .x ± 0.5 ANGULAR: .xxx $\pm 0^{\circ}30'$							外形图
UNIT: mm							USED ON
DO NOT SCALE DRAWING							SMH80S-0100-30AAK-3LKH
					FIRST ANGLE PROJECTION	SCALE	DWG NO.
						OF	REV A
							Kinco MOTOR