

## Basic specification

- ◇ Frame size : 60mm
- ◇ Voltage input: 24-60Vdc
- ◇ Encoder : 17bit incremental
- ◇ Motor with brake
- ◇ 2.5 – 3 times overload
- ◇ 4 programmable input
- ◇ 2 programmable output
- ◇ RS232 for configuration

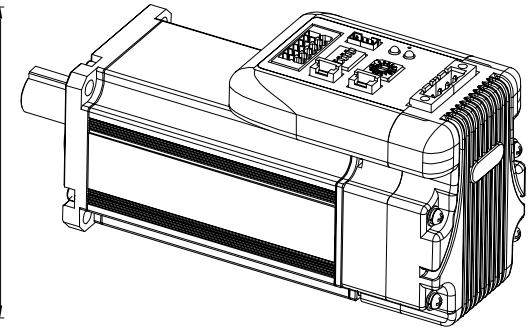

Part Number	iSV2-CAN6040V48G
Rated Power(W)	400
Rated Torque(Nm)	1.27
Peak Torque(Nm)	3.81
Rated Speed(rpm)	3000
Peak Speed(rpm)	4000
Rated Voltage(Vdc)	48
Weight(kg)	1.65
Inertia(Kg.cm <sup>2</sup> )	0.58
Torque(Nm/A)	0.127
Input Voltage(V)	24~60
Continuous Current(Arms)	10
Peak Current(A)	28
Logic Signal Current(mA)	10
Isolation Resistance(MΩ)	100
Protection Level	IP54 for motor IP20 for drive

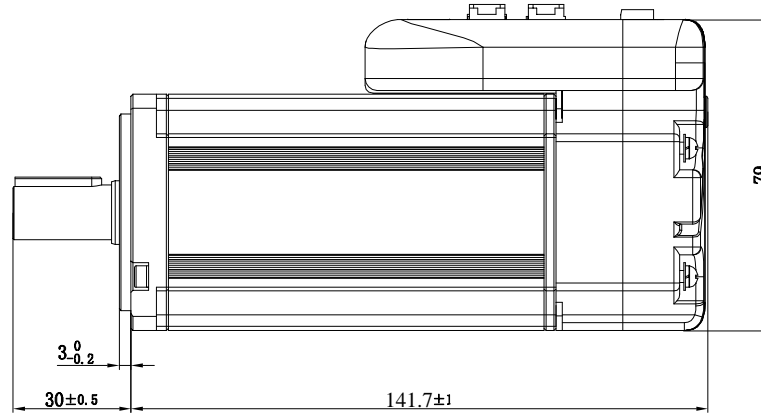
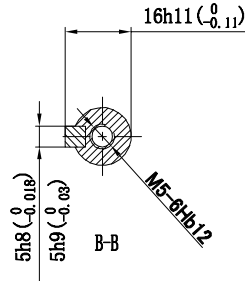
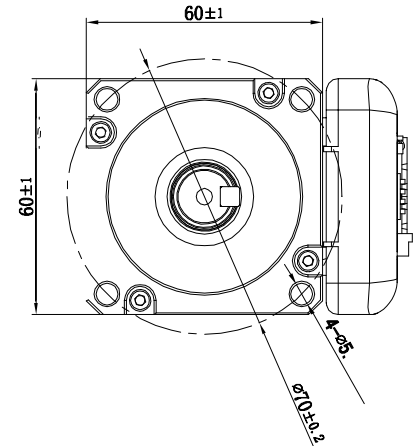
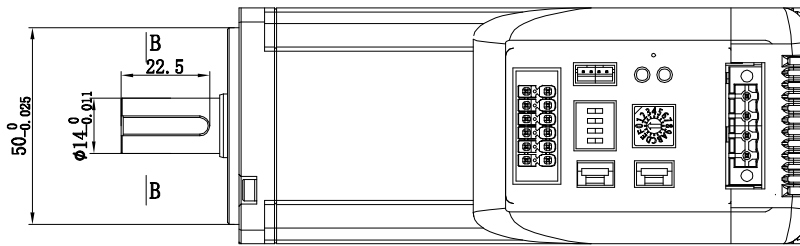

## CANopen Communication

- ◇ Link Layer Protocol : CAN Field-bus
- ◇ Application Layer Protocol : CANopen Protocol
- ◇ CAN-ID type : CAN 2.0A
- ◇ Communication Rate : 1M/500k/250k/100k/50k/20k bit/s
- ◇ Sub-protocol : DS301 V4.02 , DSP 402 V2.0
- ◇ PDO Transmission Modes :  
Time trigger/event trigger/asynchronization/synchronization
- ◇ Control mode :  
Profile position, Profile velocity , Profile torque , homing

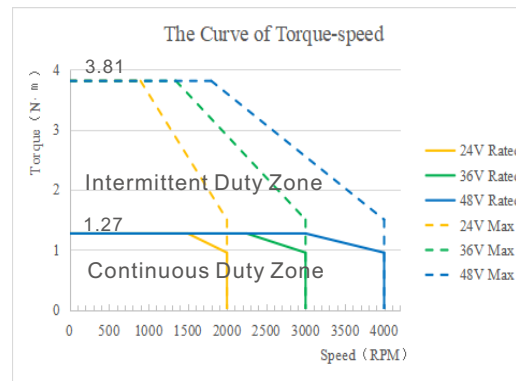

Leadshine Technology Co .Ltd

**iSV2-CAN6040V48G**

Integrated servo motor **CANopen**

48V/400watt/60mm/1.27Nm/With brake