

Efficiency: 94%
 Rated speed: 3000RPM
 Lubrication: Fully synthetic grease
 Lifetime: 20000H

Temperature: -25 °C~90 °C
 Maximum speed: 4800RPM
 Weight: 9.3KG
 IP Code: IP65

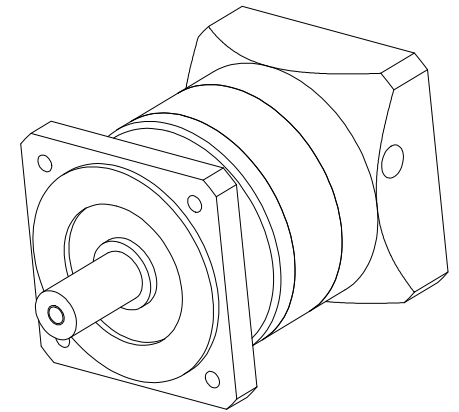

	RATIO	12	15	16	20	25	28	35	40	50	70
Rate Torque NM		250	250	250	250	264	250	264	250	264	177
Max.Torque NM	2 TIME RATE TORQUE										
Inertia KGCM ²		1.56	1.56	1.22	1.15	1.15	1.13	1.13	1.11	1.11	1.11
Radial Force N		2230									
Axial Force N		1550									

	FDL						

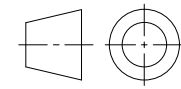

AE-120-xx-S2

