

# EL7-EC Series AC Servo Drives - 220V

EL7-EC Series AC servo products 220V are high performance AC digital servo which is designed for position/velocity/torque high accurate control with power rating ranging up to 2kW which provides a perfect solution for different applications with easy tuning process.

EL7-EC series AC servo drives are using the latest Digital Signal Processing (DSP) chip and Intelligent Power Module (IPM) with compact components integration and great reliability. Using the best PID calculation for Pulse Width Modulation (PWM) control, our EL7-EC series products are the one to beat in this product category.

## Highlights:

- ① Easy tuning
- ② ETG COE + EtherCAT DSP402 communication protocol
- ③ Internal regenerative resistor
- ④ Equipped with notch filter, damping filter
- ⑤ Comes with Safe Torque Off (STO) SIL3
- ⑥ Motors automatically identified
- ⑦ Motors with holding brake
- ⑧ 23-bit multiturn magnetic/optical encoder



## Technical Specification

EL7-EC series	EL7-EC400F	EL7-EC750F	EL7-EC1000F	EL7-EC1500F	EL7-EC2000F
Rated power (W)	400	750	100	1500	2000
Rated Current (A)	3.5	5.5	7	<i>Coming Soon!</i>	
Peak Current (A)	9.2	16.6	18.7		
Size (mm)	40*175*156	50*175*156			
Main Power Supply		Single phase AC 220V, -15%~+10%, 50/60Hz			
Control Circuit Power Supply					
Drive mode		IGBT PWM sinusoidal wave drive			
Control mode	Position	Profile Position Mode (PP)			
		Cyclic Synchronous Position Mode (CSP)			
		Homing Mode (HM)			
	Velocity	Profile Velocity Mode (PV)			
		Cyclic Synchronous Velocity Mode (CSV)			
	Torque	Profile Torque Mode (PT)			
Cyclic Synchronous Torque Mode (CST)					
Encoder Feedback		RS485 protocol: 23-bit multiturn absolute magnetic/optical encoder			
I/O	Digital Input	4 Digital Inputs (Supports NPN and PNP)		1. Clear Alarm (A-CLR) 2. Positive limit switch (POT) 3. Negative limit switch (NOT) 4. Homing switch (HOME-SWITCH) 5. Emergency stop (E-Stop)	
	Digital Output	Configurable input signals under EtherCAT mode:			

		Configurable output signals under EtherCAT mode:	<ol style="list-style-type: none"> <li>1. Alarm (ALM)</li> <li>2. Servo ready (SRDY)</li> <li>3. External brake off (BRK-OFF)</li> <li>4. Positioning completed (INP)</li> <li>5. Velocity at arrival (AT-SPEED)</li> <li>6. Torque limiting command (TLC)</li> <li>7. Zero speed position (ZSP)</li> <li>8. Velocity coincidence (V-COIN)</li> <li>9. Position command (P-CMD)</li> <li>10. Velocity limit (V-LIMIT)</li> <li>11. Velocity command (V-CMD)</li> <li>12. Servo enabled (SRV-ST)</li> <li>13. Homing done (HOME-OK)</li> </ol>
	<b>Encoder Output</b>	Encoder ABZ differential pulse output	
	<b>Probe Input</b>	2 high speed probe inputs: EXT1+/EXT1-, EXT2+/EXT2-	
<b>Communication Port</b>	<b>USB mini</b>	Modbus USB2.0 (No need to connect driver to power supply)	
	<b>EtherCAT</b>	EtherCAT, Communication up to 128 axes to a host	
<b>Software</b>		Driver tuning through <b>Motion Studio</b> Ver. 1.4.x. Parameters tuning in current loop, position loop, velocity loop; Modify I/O signal and motor parameters; Variables(velocity, position deviation, etc.) monitoring using step diagrams	
<b>Driver Front Panel</b>		5 push buttons and 8-segments display	
<b>Holding brake</b>		Built-in (Supports external brake)	
<b>Safety Protection</b>		Overcurrent. Overvoltage. Undervoltage. Overheat. Overload. Overtravel. Single-Phasing. Regenerative resistor error. Position deviation error. Encoder feedback error. Excessive braking rate. EEPROM error	
<b>Safe Torque Off (STO) function</b>		Available for all EL7EC-F series products	
<b>Environment</b>	<b>Temperature</b>	Storage: -20-80°C (Condensation free); Installation: 0-55°C (Not frozen)	
	<b>Humidity</b>	Under 90%RH (Condensation free)	
	<b>Altitude</b>	Up to 1000m above sea level	
	<b>Vibration</b>	Less than 0.5G (4.9m/s <sup>2</sup> ) 10-60Hz (non-continuous working)	
	<b>IP ratings</b>	IP20	

## Servo Drive Features

<b>Inertia ratio determination</b>
Simple online and offline inertia ratio determination to simplify servo drive tuning.
<b>Control mode switching</b>
Position/Velocity/Torque mode can be switched easily by delivering an I/O signal.
<b>Auto gain adjustment</b>
Measure real time mechanical stiffness and set gain values automatically.
<b>Gain switching</b>
Automatically switch gain to suppress vibration, shorten positioning time and improve following behavior.
<b>Feedforward gain</b>
Reduce position deviation and increase system responsiveness. Including velocity and torque feedforward.
<b>Vibration Suppression</b>
Suppress mechanical resonance and mechanical end vibration by applying filters.
<b>Model following control</b>
Reference model to improve responsiveness to command and closed loop control to increase responsiveness towards interference.
<b>Friction compensation</b>
Compensate for changes in load to reduce the effect of friction on motion.

**EL7-EC Servo Drive**

# EL7-EC 750 F

①      ②      ③      ④

No.	Description			
①	Series No.	EL7: Servo drive series		
②	Command source	P: Pulse + direction	EC: EtherCAT	
③	Power rating	400: 400W	750: 750W	1000:1000W
		1500: 1500W	2000: 2000W	
④	Type	F: Full functions		

## Ports and connectors

### CN1 I/O Signal Port

CN1 connector is a 16-pin spring loaded connector.

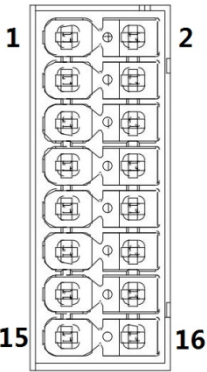
Port	Pin	Signal	Description	Remarks
	1	EXT1+	Probe 1 positive terminal	2 high speed probe inputs function
	2	EXT2+	Probe 2 positive terminal	
	3	NC	Reserved	
	4	NC	Reserved	
	5	EXT1 -	Probe 1 negative terminal	
	6	EXT2 -	Probe 2 negative terminal	
	7	DICOM	Common DI	Double-ended common DI Configurable Recommended voltage: 12VDC - 24VDC
	9	DI1	Reserved	
	11	DI2	POT: Positive limit switch	
	13	DI3	NOT: Negative limit switch	
	15	DI4	HOME: Homing done	
	8	D01	ALM: Alarm	D01,D02: Single-ended D03: Double-ended Configurable Recommended voltage: 12Vdc - 24Vdc, max 30V Recommended current: 10mA, max 50mA
	10	D02	BRK-OFF: Holding brake activated	
	12	D03+	INP: Positioning completed	
	14	D03-		
	16	DOCOM	Common DO	

### CN2 Encoder

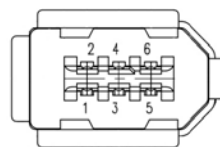

Connector	Pin	Signal	Description
CN2	1	VCC5V	Power supply 5V
	2	GND	Power supply ground
	3	BAT+	Battery positive terminal
	4	BAT-	Battery negative terminal
	5	SD+	SSI Data+
	6	SD-	SSI Data-
	Frame	PE	Shield grounding

**USB mini Communication Port**

Parameters tuning on Motion Studio can be done without connecting main power supply to driver.

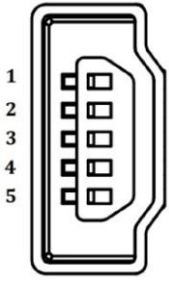
Connector	Port	Pin	Signal	Description
USB mini		1	VCC5V	Power supply 5V
		2	D+	USB data positive terminal
		3	D-	USB data negative terminal
		4	--	--
		5	GND	Power supply ground
		Frame	USB_GN D	Ground through capacitor

**CN3/CN4 EtherCAT Communication Port**

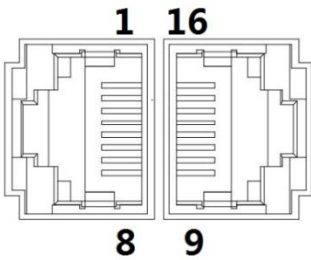
Port	Pin	Signal	Description
	1, 9	E_TX+	EtherCAT Data sending positive terminal
	2, 10	E_TX-	EtherCAT Data sending negative terminal
	3, 11	E_RX+	EtherCAT Data receiving positive terminal
	4, 12	--	--
	5, 13	--	--
	6, 14	E_RX-	EtherCAT Data receiving negative terminal
	7, 15	--	--
	8, 16	--	--
	Frame	PE	Shielded ground

**CN6 Safe Torque Off (STO) Port**

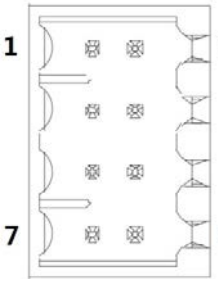
Port	Pin	Signal	Description	Remarks
	1	24V	24v power supply	Connect to SF1 and SF2 when not in use. Do not use to supply power.
	2	0V	Reference ground	
	3	SF1+	Control signal 1 positive input	When SF1 = OFF or SF2 = OFF,STO is enabled.
	4	SF1-	Control signal 1 negative input	
	5	SF2+	Control signal 2 positive input	
	6	SF2-	Control signal 2 negative input	
	7	EDM+	External monitoring device (EDM) with differential double ended output	When SF1 = OFF or SF2 = OFF,EDM = ON
	8	EDM-		

**CN5 Frequency divider pulse output port**

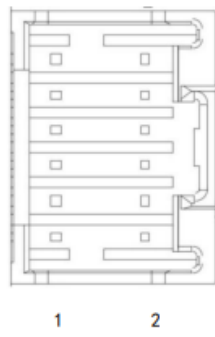
Port	Diagram	Pin	Signal	Label
	11	A+	Motor encoder phase A frequency divider output	
	12	A-		
	9	B+	Motor encoder phase B frequency divider output	
	10	B-		
	7	Z+	Motor encoder phase Z frequency divider output	
	8	Z-		
	5	OCZ	Motor encoder Z-signal OC output	
	6	GND	Motor encoder Z-signal OF output reference ground	
	3	/	/	
	4	/	/	
	1	PE	Shield grounding	
	2	/	/	

**X1 Main Power Supply Port**

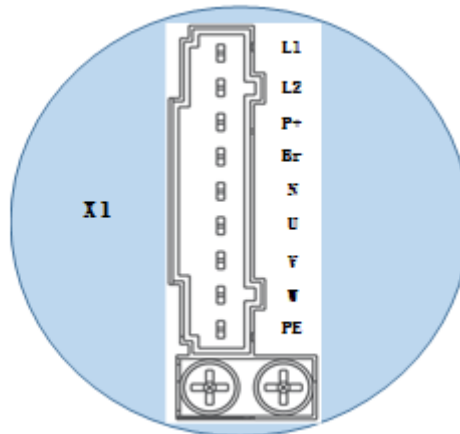

Port	Pin	Functions	Remarks
X1	L1	Single phase 220VAC, +10 ~ -15%, 50/60Hz	① Optional isolation transformer ② Do not connect to 380VAC directly to prevent damage to driver. ③ In case of serious interference, it is recommended to connect a line filter to main power supply; <i>It is recommended to install a fuseless circuit breaker to cut off power supply in time when the driver fails.</i>
	L2		
	P +	① Internal DC bus positive terminal ② External regenerative resistor P terminal	
	Br	External regenerative resistor terminal	<i>Please refer to 2.4.1 Regenerative resistor selection and connections</i>
	N		
	U	Motor U terminal	Please ensure proper wire connection on motor.
	V	Motor V terminal	
	W	Motor W terminal	
	PE	Motor Protective Earth	Please ground PE of driver and motor together

# EL7-EC Series AC Servo Drives - 380V

EL7-EC Series AC Servo products are high-performing servo drivers using latest digital signal processing (DSP) chip and intelligent power module (IPM). The series comes with highly compacted integration, small volume and great reliability. Also highly competitive using our best PID controls for pulse width modulation (PWM).

We worked on cutting down the complexity of wiring work but at the same time also improved the motion control capability of the servo drivers. This product series not only upgraded with better protection against communication interference, it can be connected over longer distances.

**Features:**

- ① Easy tuning
- ② ETG COE + EtherCAT DSP402 communication protocol
- ③ Internal regenerative resistor
- ④ Equipped with notch filter, damping filter
- ⑤ Motors automatically identified
- ⑥ Motors with holding brake
- ⑦ 23-bit multiturn magnetic/optical encoder



## Technical Specifications

EL7-EC series	EL7-EC750FT	EL7-EC1000FT	EL7-EC1500FT	EL7-EC2000FT	EL7-EC3000FT	EL7-EC4400FT	EL7-EC5500FT	EL7-EC7500FT	
Rated power(W)	750	1000	1500	2000	3000	4400	5500	7500	
Rated Current	2.7	3.5	5.4	8.4	11.9	16.5	20.8	25.7	
Peak Current	8.6	10.6	14.9	24.8	33.2	38.9	51.6	63.6	
Size (mm)	55*175*179			80*175*179		89*250*230			
Main Power Supply	Three phase AC 380V~440V, -15%~+10%, 50/60Hz								
Control Circuit Power Supply	Single phase AC 380V~440V, -15%~+10%, 50/60Hz								
Drive mode	IGBT PWM sinusoidal wave drive								
Encoder Feedback	RS485 protocol: 23-bit multiturn absolute magnetic/optical encoder								
I/O	Digital Input	4 Digital Inputs (Supports NPN and PNP)							
		Configurable input signals under EtherCAT mode:						1. Clear Alarm (A-CLR) 2. Positive limit switch (POT) 3. Negative limit switch (NOT) 4. Homing switch (HOME-SWITCH) 5. Emergency stop (E-Stop)	
	Digital Output	3 Digital Outputs (2 single-ended, 1 differential)							
		Configurable output signals under EtherCAT mode:						1. Alarm (ALM) 2. Servo ready (SRDY) 3. External brake off (BRK-OFF) 4. Positioning completed (INP) 5. Velocity at arrival (AT-SPEED) 6. Torque limiting command (TLC) 7. Zero speed position (ZSP) 8. Velocity coincidence (V-COIN) 9. Position command (P-CMD) 10. Velocity limit (V-LIMIT) 11. Velocity command (V-CMD) 12. Servo enabled (SRV-ST) 13. Homing done (HOME-OK)	
	Analog Input	2 analog inputs (differential), -10~+10Vdc							
	Encoder Output	Encoder ABZ differential pulse output (Only available for EL7-EC***FT series products)							
Probe Input	2 high speed probe inputs: EXT1+/EXT1-, EXT2+/EXT2-								



Communication Port	USB mini	Modbus USB2.0 (No need to connect driver to power supply)
	EtherCAT	EtherCAT, Communication up to 128 axes to a host
Software		Driver tuning through <b>Motion Studio</b> Ver. 1.4.x. Parameters tuning in current loop, position loop, velocity loop; Modify I/O signal and motor parameters; Variables(velocity, position deviation, etc.) monitoring using stepper diagrams
Driver Front Panel		5 push buttons and 7-segments display
Holding brake		Built-in (Supports external brake)
Safety Protection		Overcurrent. Overvoltage. Undervoltage. Overheat. Overload. Overtravel. Single-Phasing. Regenerative resistor error. Position deviation error. Encoder feedback error. Excessive braking rate. EEPROM error
Safe Torque Off (STO) function		Available for all EL7-EC***FT series products
Environment	Temperature	Storage: -20-80°C (Condensation free); Installation: 0-55°C (Not frozen)
	Humidity	Under 90%RH (Condensation free)
	Altitude	Up to 1000m above sea level
	Vibration	Less than 0.5G (4.9m/s <sup>2</sup> ) 10-60Hz (non-continuous working)
	IP ratings	IP20

### Model Number Structure

#### EL7-EC 380V Series AC Servo Driver

EL7 - EC 2000 F T  
 ①      ②      ③      ④      ⑤

No.	Details	
①	Series Number	EL7: New servo driver series
②	Command source	EC: EtherCAT
③	Rated power	750:750W    1000:1000W    1500: 1500W    2000: 2000W    3000: 3000W 4400:4400W    5500: 5500W    7500: 7500W
④	Version	F: Full functions version
⑤	Power Supply	T: 380VAC

**Ports**

**CN1 – Control signal port**

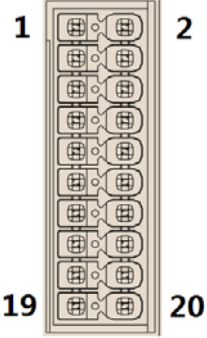
Port		Pin	Signal	Explanation	
CN1		1	EXT1+	Probe 1 input positive terminal	
		2	EXT2+	Probe 2 input negative terminal	
		3	-	-	
		4	-	-	
		5	EXT1-	Probe 1 input positive terminal	
		6	EXT2-	Probe 2 input negative terminal	
		7	DICOM	DI common terminal	Configurable Recommended voltage: 12Vdc – 24Vdc
		9	DI1	DI signal 1	
		11	DI2	DI signal 2	
		13	DI3	DI signal 3	
		15	DI4	DI signal 4	Configurable Recommended voltage: 12Vdc – 24Vdc, max 30V Recommended current: 10mA, max 50mA
		8	DO1	Single ended DO signal 1	
		10	DO2	Single ended DO signal 2	
		12	DO3 +	Differential double-ended DO signal 3	
		14	DO3 -		
		16	DOCOM	DO common terminal	Differential Input current: -10Vdc - +10Vdc Input resistance: 20kΩ
		17	AI2 +	AI 2 positive terminal	
		19	AI2 -	AI 2 negative terminal	
		18	AI1 +	AI 1 positive terminal	
		20	AI1 -	AI 1 negative terminal	

**CN2 – Encoder input port**

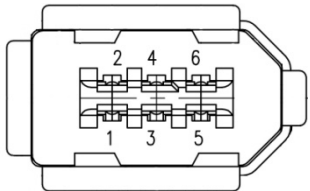
Port		Pin	Signal	Explanation
CN2		1	VCC5V	Power supply 5V
		2	GND	Power supply ground
		3	BAT+	Battery positive terminal
		4	BAT-	Battery negative terminal
		5	SD+	SSI Data+
		6	SD-	SSI Data-
		Frame	PE	Shield grounding

**EtherCAT Communication Port – CN3 & CN4**

Port		Pin	Signal	Explanation
CN3 CN4		1, 9	E_TX+	EtherCAT Transmission Data +
		2, 10	E_TX-	EtherCAT Transmission Data -
		3, 11	E_RX+	EtherCAT Receiver Data +
		4, 12	-	-
		5, 13	-	-
		6, 14	E_RX-	EtherCAT Receiver Data -
		7, 15	-	-
		8, 16	-	-
		Frame	PE	Shield grounding

**Encoder Pulse Output Port - CN5**

Port		Pin	Signal	Explanation	
CN5		11	A+	Encoder channel A crossover's output	Differential High level ≥2.5Vdc Low level ≤0.5Vdc Current range ±20mA
		12	A-		
		9	B+	Encoder channel B crossover's output	
		10	B-		
		7	Z+	Encoder channel Z crossover's output	
		8	Z-		
		5	OCZ	Encoder Z signal OC output (NPN)	
		6	GND	Encoder Z signal OC reference ground	
		2	-	-	
		3	-	-	
		4	-	-	
		1	PE	Ground terminal for shielded	
		2	-	-	

**Safe Torque Off (STO) Port – CN6**

Port		Pin	Signal	Label	Explanation	
CN6		1	24V	24v power supply	Connect to SF1 and SF2 when not in use. Do not use to supply power.	
		2	0V	Reference ground		
		3	SF1 +	Control signal positive input	1	When SF1 = OFF or SF2 = OFF, STO is enabled.
		4	SF1 -	Control signal negative input	1	
		5	SF2 +	Control signal positive input	2	
		6	SF2 -	Control signal negative input	2	
		7	EDM +	External monitoring device (EDM) with differential double ended output	When SF1 = OFF or SF2 = OFF, EDM = ON	
		8	EDM -			

**USB Mini Communication Port**

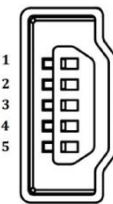
Port		Pin	Signal	Explanation
USB		1	VCC5V	Power supply positive terminal 5V
		2	D+	USB data +
		3	D-	USB data -
		4	-	-
		5	GND	Power supply negative terminal
		Frame	USB_GND	Ground

**Main Circuit Port**

Port		Pin	Signal	Explanation	Remarks	
Main Circuit Port		L1C	L1C	Control circuit power supply L1	Single phase AC 380V~440V, -15%~+10%, 50/60Hz	① Isolation transformer can be used for power supply; ② In case of serious interference, it is recommended to use line filter for power supply; ③ It is recommended to install a non-fusible circuit breaker to cut off external power supply in time when the drive fails.
		L2C	L2C	Control circuit power supply L2		
		P+	R	Main power supply R terminal	Three phase AC 380V~440V, -15%~+10%, 50/60Hz	
		B1	S	Main power supply S terminal		
		B2	T	Main power supply T terminal		
		N				
		U	P+	DC bus + terminal	drive DC bus + terminal External regenerative resistor P terminal	① Built-in regenerative resistor, connect B1 and B2; ② External regenerative resistor, disconnect B1 and B2; Connect external regenerative resistor between N1 and N2.
		B1	B1	Built-in regenerative resistor terminal	Built-in regenerative resistor terminal	
		B2	B2	Built-in/ External regenerative resistor terminal	Built-in/ External regenerative resistor terminal	N1 is usually connected to N2. Connect to a DC reactor when suppression of higher harmonics from power supply is needed. Don't connect anything to N.
		N2	N1	DC bus - terminal	Internal DC bus negative terminal	
		N1	N			
		P+	U	U terminal	3 phase motor power supply	① Connect driver's UVW to corresponding terminals on motor. ② Connect the drive to the ground terminal (PE) of the motor and connect it to the earth
		B1	V	V terminal		
		B2	W	W terminal		
		U	PE	PE	Frame ground	

Servo Motor Dimension

ELM SERIES 130 BASE MOTOR (850W/1300W/1800W)

380V

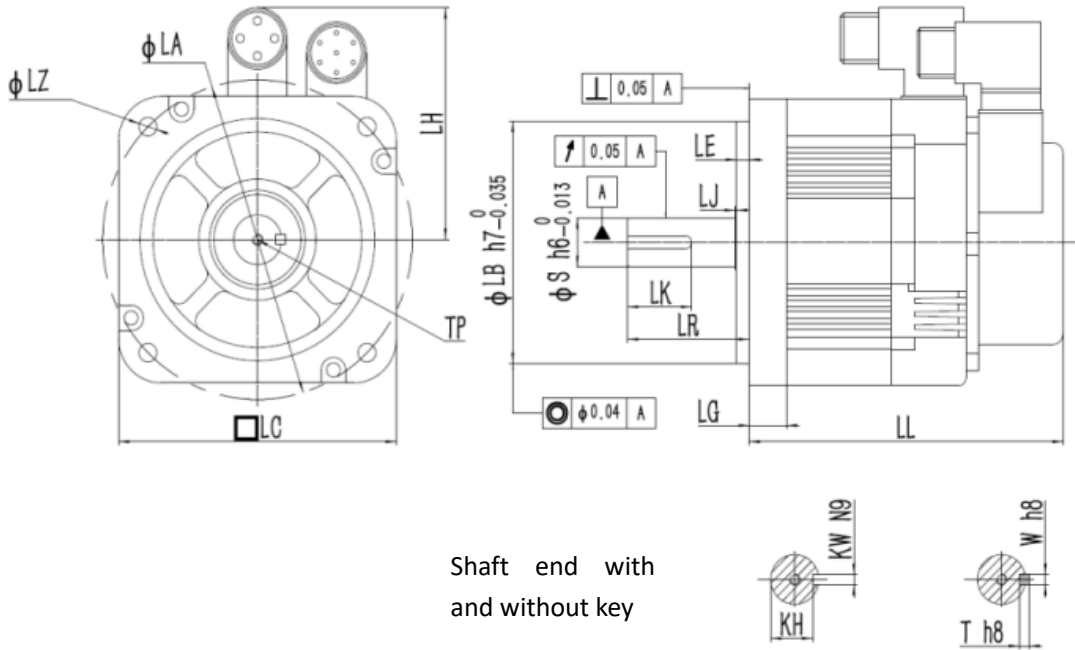

Shaft end with and without key

Model no.	LL	LC	LR	LA	LZ	LH	LG	LE	LJ	S	LB	TP	LK	KH	KW	V	T
ELM2H-0850LD 130FT-H	147	130	57	145	8.5	106	17.5	6	0.5	19	110	M5x12	30	16	5	5	5
ELM2H-0850LD 130ET-H	172	130	57	145	8.5	106	17.5	6	0.5	19	110	M5x12	30	16	5	5	5
ELM2H-1300LD 130FT-H	168	130	57	145	8.5	106	17.5	6	0.5	22	110	M5x12	30	18.5	6	6	6
ELM2H-1300LD 130ET-H	192	130	57	145	8.5	106	17.5	6	0.5	22	110	M5x12	30	18.5	6	6	6
ELM2H-1800LD 130FT-H	195	130	57	145	8.5	106	17.5	6	0.5	24	110	M5x12	30	19	8	8	8
ELM2H-1800LD 130ET-H	219	130	57	145	8.5	106	17.5	6	0.5	24	110	M5x12	30	19	8	8	8

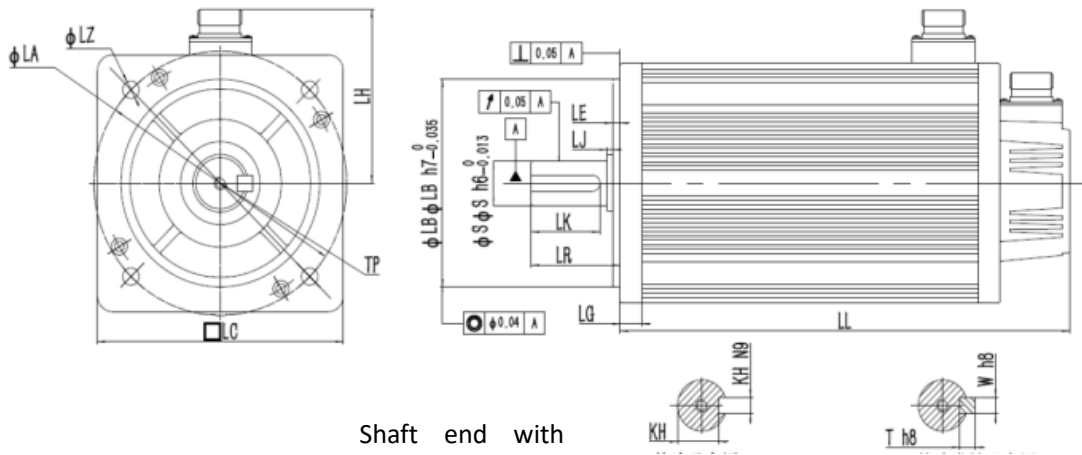

Shaft end with and without key

Model no.	LL	LC	LR	LA	LZ	LH	LG	LE	LJ	S	LB	TP	LK	KH	KW	V	T
ELM13030M3F*	231	131	57	145	9	111	14	5	2	22	110	M6x20	40	18.5	6	6	6
ELM13030M3E*	312	131	57	145	9	111	14	5	2	22	110	M6x20	40	18.5	6	6	6

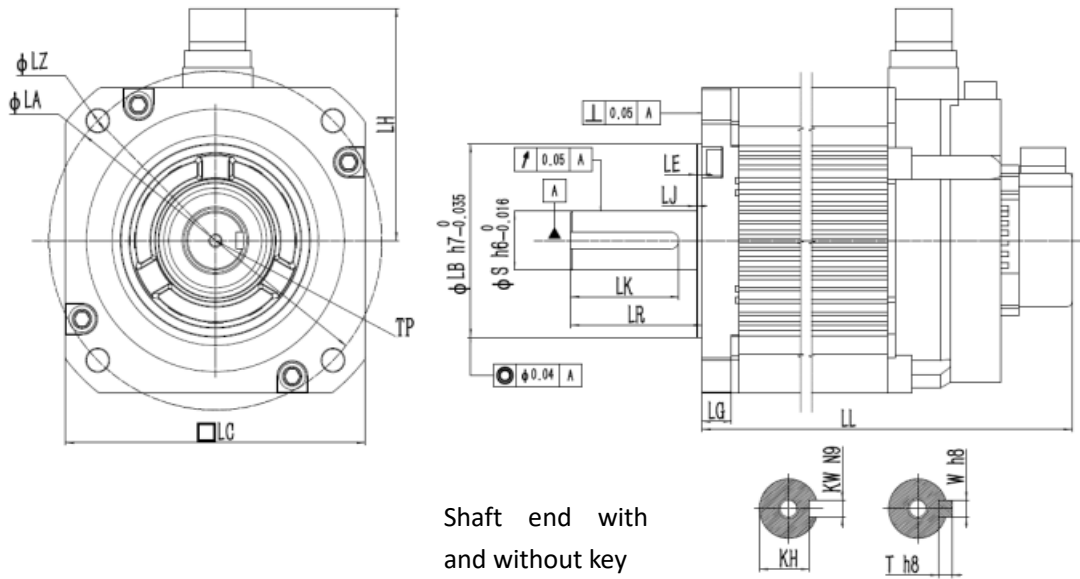

Shaft end with and without key

Model no.	LL	LC	LR	LA	LZ	LH	L G	LE	LJ	S	LB	TP	LK	KH	KW	W	T
ELM2M-2900LD 180FT-H	201	180	79	200	4-φ13.5	134	18	3.2	0.3	35	114	M12x25	65	30	10	10	8
ELM2M-2900LD 180ET-H	249	180	79	200	4-φ13.5	134	18	3.2	0.3	35	114	M12x25	65	30	10	10	8
ELM2M-4400LD 180FT-H	230	180	79	200	4-φ13.5	134	18	3.2	0.3	35	114	M12x25	65	30	10	10	8
ELM2M-4400LD 180ET-H	278	180	79	200	4-φ13.5	134	18	3.2	0.3	35	114	M12x25	65	30	10	10	8
ELM2M-5500LD 180FT-H	257	180	113	200	4-φ13.5	134	18	3.2	0.3	42	114	M16x32	96	37	12	12	8
ELM2M-5500LD 180ET-H	305	180	113	200	4-φ13.5	134	18	3.2	0.3	42	114	M16x32	96	37	12	12	8
ELM2M-7500LD 180FT-H	297	180	113	200	4-φ13.5	134	18	3.2	0.3	42	114	M16x32	96	37	12	12	8
ELM2M-7500LD 180ET-H	345	180	113	200	4-φ13.5	134	18	3.2	0.3	42	114	M16x32	96	37	12	12	8

# EL7-RS Series AC Servo Drives – 220VAC

EL7-RS Series AC Servo Product is a whole new midrange AC servo drivers and motors product range that we have proudly developed at Leadshine Technology Co.,Ltd. This product series provides more in demanded functionalities and control. While designing this AC servo drive series with cost concerns in mind, this product series doesn't compromise in term of performance and functions.

EL7-RS Series AC Servo Drive comes with power rating from 450W up to 2000W which supports Modbus communication protocol in addition to analogue and pulse + direction input control.

EL7-RS series AC Servo Drive is equipped with easy servo tuning (One-click Tuning/ Single Parameter Tuning), Zero Tracking Control (ZTC), vibration suppression and many more. This AC servo drive series also comes with new AC servo motors with 23-bit optical/magnetic encoder which offers better accuracy and stability.

## Highlights

- ① I/Os: 8 DI, 5 DO, 2 AI, 1 AO
- ② Easy Tuning
- ③ Modbus RTU/Pulse+Direction/Analogue
- ④ Pulse input:
  - High speed – 4MHz,
  - Low speed – 200kHz (24V), 500kHz(5V)
- ⑤ Up to 16 highly configurable PR paths in PR mode
- ⑥ Motors with optional holding brake
- ⑦ Motors automatically identified once connected
- ⑧ 23-bit multiturn magnetic/optical encoder



## Technical Specifications

EL7-RSP Series Driver		EL7-RS400P	EL7-RS750P	EL7-RS1000P	EL7-RS1500P	EL7-RS2000P
<b>Power Rating</b>		400W	750W	1000W	<i>Coming Soon!</i>	
<b>Rated Current (Arms)</b>		3.5	5.5	7.0		
<b>Peak Current (Arms)</b>		9.5	16.6	18.7		
<b>Control circuit power supply</b>		1-Ph AC 200V-240V, -10% - +10%, 50/60Hz				
<b>Main power supply</b>		1-Ph AC 200V-240V, -10% - +10%, 50/60Hz				
<b>Regenerative resistor</b>	<b>Resistance(Ω)</b>	Not provided	50		50	
	<b>Power rating(W)</b>		75		80	
<b>Cooling method</b>		Air-cooled	Fan-cooled			
<b>Dimension H*L*W(mm)</b>		175*156*40	175*156*50		175*156*80	
Port		Descriptions				
<b>USB Type-C Tuning</b>		Modify or read driver parameters without connecting to main power supply				
<b>Low-speed pulse input</b>		5V differential signal, 0-500kHz 24V single ended signal, 0-200kHz				
<b>High-speed pulse input</b>		5V differential signal, 0-4MHz				
<b>Crossover Frequency Output</b>		Supports phase A/B/Z differential crossover frequency output Supports phase Z open collector crossover frequency output				
<b>Analog Input</b>		2 analog inputs (AI1/AI2) , -10V~+10V, Max. voltage: ±12V				
<b>Analog Output</b>		1 analog output (AO1) , -10V~+10V				
<b>Digital Input</b>		8 Digital Inputs (Supports common anode or cathode connection) DI1~DI8 1. Servo enabled (SRV-ON)				



		2. Positive limit switch (POT) 3. Negative limit switch (NOT) 4. Gain switching (GAIN) 5. Emergency stop (E-Stop) 6. Deviation counter clearing (CL) 7. Control mode switching (C-MODE) 8. Torque limit switching (TL-SEL) 9. Vibration suppression 1(VS-SEL1) 10. Vibration suppression 2(VS-SEL2) 11. Command prohibition(INH) 12. Internal command velocity 1(INTSPD1) 13. Internal command velocity 2(INTSPD2) 14. Internal command velocity 3(INTSPD3) 15. Crossover frequency input(DIV1) 16. Zero speed clamp(ZEROSPD) 17. Velocity sign(VC-SIGN) 18. Torque sign(TC-SIGN) 19. Clear Alarm (A-CLR) <i>Under PR mode</i> 1. Path trigger (CTRG) 2. Home switch (HOME) 3. Emergency stop trigger(STP) 4. Path 0-3 (ADD0-ADD3) 5. Positive JOG (PJOG) 6. Negative JOG(NJOG) 7. Positive limit switch(PL) 8. Negative limit switch(NL) 9. Origin(ORG)
	<b>Digital Output</b>	5 digital outputs (double-ended) DO1~DO5 1. Alarm (ALARM) 2. Servo ready (SRDY) 3. External brake off (BRK-OFF) 4. Positioning completed (INP1) 5. Velocity at arrival (AT-SPEED) 6. Zero speed position (ZSP) 7. Velocity coincidence (V-COIN) 8. Position command (P-CMD) 9. Velocity limit (V-LIMIT) 10. Velocity command (V-CMD) 11. Servo enabled (SRV-ST) 12. Positive limit switch(POT-OUT) 13. Negative limit switch (NOT-OUT) <i>Under PR mode</i> 1. Command completed (CMD-OK) 2. Path completed (PR-OK) 3. Homing done (HOME-OK)
	<b>Communication Port</b>	RS485 communication, Modbus RTU protocol (RJ45 port)
<b>Control Mode</b>		
	<b>Control</b>	1. External pulse train position control 2. JOG control 3. Velocity control 4. Torque control 5. Hybrid control: Position-Torque/Position-Velocity/Velocity-Torque
<b>Position</b>	<b>Pulse frequency</b>	<ul style="list-style-type: none"> <li>• 4MHz (5V differential input)</li> <li>• 500kHz (5V differential input)</li> <li>• 200kHz (24V single-ended input)</li> </ul>
	<b>Electronic gear ratio</b>	(1~8388608) / (1~8388608)
	<b>Torque limit</b>	<i>Please refer to parameter settings</i>

Control Features		
<b>Drive Mode</b>	IGBT SVPWM sinusoidal wave drive	
<b>Feedback Method</b>	Encoder: RS485 Protocol	
<b>Standardized Parameters</b>	Quick tuning of servo driver parameters can be achieved through PC tuning tools.	
<b>Easy-to-use</b>	One-click tuning, Single parameter tuning, Black box, Zero tracking control	
<b>Notch Filter</b>	Mechanical resonance suppression. Supports up to 3 filters,50Hz~4000Hz	
<b>Vibration suppression</b>	End vibration suppression	
<b>DI/DO settings</b>	Digital inputs and outputs are user-configurable	
<b>Alarm</b>	Overcurrent. Overvoltage. Undervoltage. Overheat. Overload. Overtravel. Single-Phasing. Regenerative resistor error. Position deviation error. Encoder feedback error. Excessive braking rate. EEPROM error	
<b>Front Panel</b>	5 push buttons, 8-segments display	
<b>Software</b>	Driver tuning through <b>Motion Studio</b> Ver. 2.2.x. Parameters tuning in current loop, position loop, velocity loop; Modify I/O signal and motor parameters; Variables(velocity, position deviation, etc.) monitoring using step diagrams'	
<b>Communication</b>	<b>USB Type-C</b>	Modbus USB2.0 (No need to connect driver to power supply)
	<b>Modbus</b>	RS485 communication, Modbus RTU protocol (RJ45 port). Communication up to 32 axes to a host.
<b>Dynamic Brake</b>	Internal dynamic brake	
<b>Black Box</b>	Set triggering conditions and analyze the data from black box. Used for error solving	
<b>Suitable Load Inertia</b>	30 times smaller than motor inertia	
Environmental requirements		
<b>Temperature</b>	Storage: -20-80℃ (Condensation free); Not < 72 hours if stored in over 65℃ Installation: 0-55℃ (Not frozen); Lower performance at over 45℃	
<b>Humidity</b>	Under 90%RH (Condensation free)	
<b>Altitude</b>	Max. altitude of 2000m; 100% performance at 1000m or below. Performance decreases by 1% with every increase of 100m from 1000m.	
<b>Vibration</b>	Less than 0.5G (4.9m/s <sup>2</sup> ) 10-60Hz (non-continuous working)	
<b>IP ratings</b>	IP20	

## Servo Drive Features

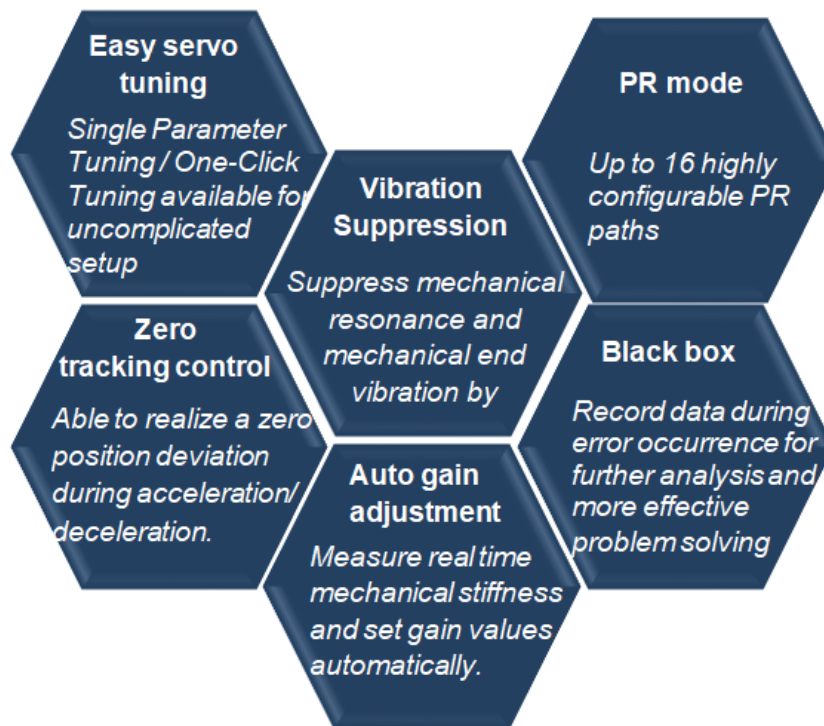

## Model Name Structure

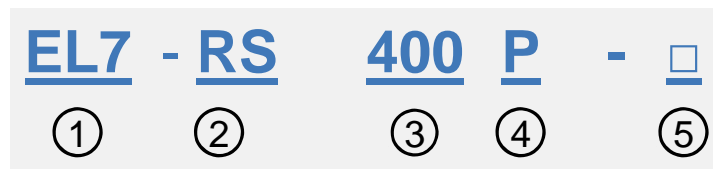

No.	Description	
①	Series No.	EL7: EL7 AC Servo Drive Series
②	Communication protocol	RS: Pulse train + RS485 + Analogue EC: EtherCAT
③	Power Rating	400: 400W    750: 750W 1000:1000W    1500: 1500W    2000: 2000W
④	Type	P: Full functions without STO
⑤	Extra(customized)	Blank: Standard

## Ports and Connectors

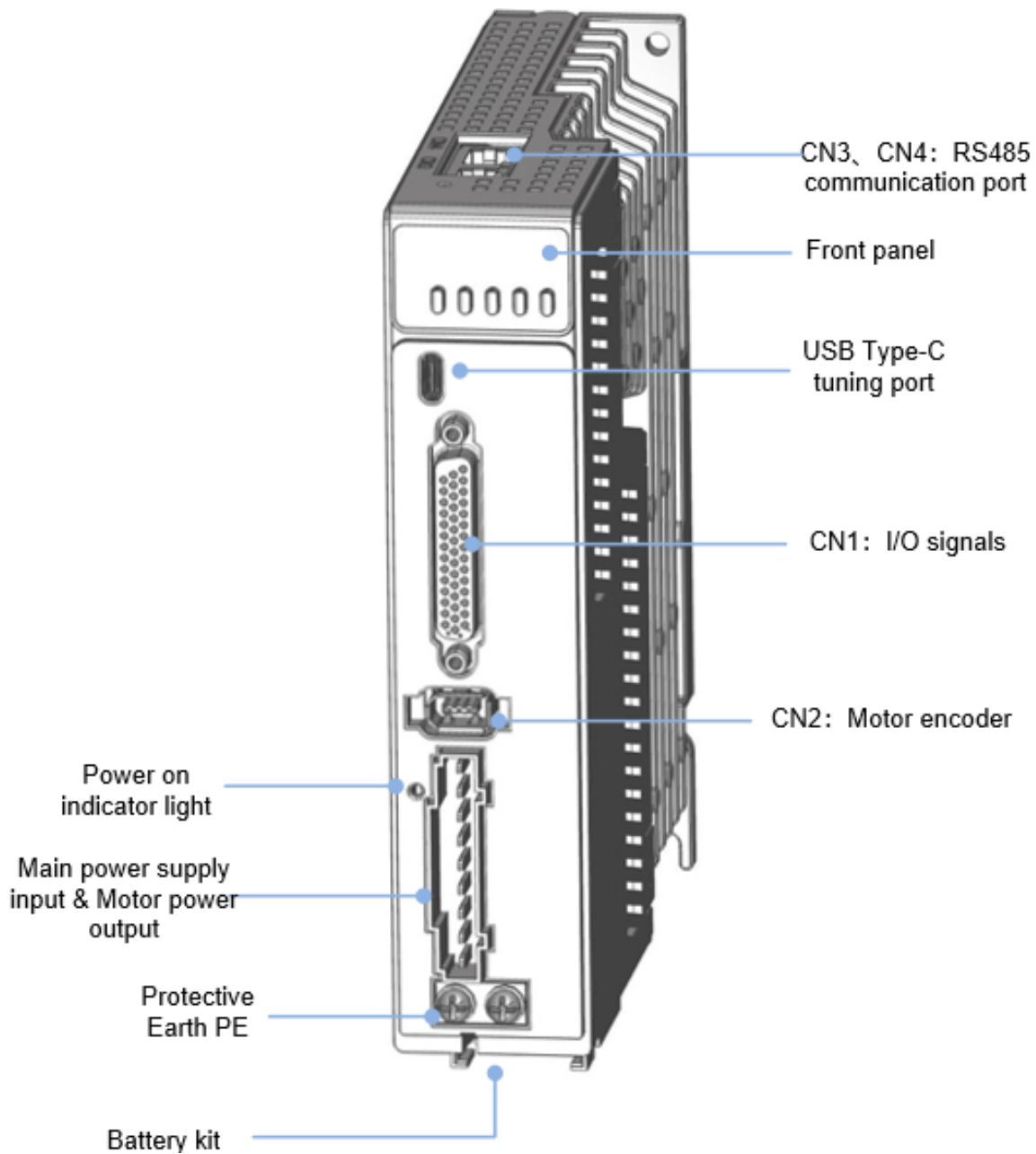

Connector	Label
CN1	I/O signal connector (DB 44PIN)
CN2	Motor encoder feedback
CN3	RS485 Communication port
CN4	RS485 Communication port
X1	Main circuit power supply/ Motor power output
PC	USB type-C tuning port
PE	Protective Earth for grounding

# CN1 - I/O Control Signal

EL7-RS Series Servo Drive uses DB 44-Pin connector.

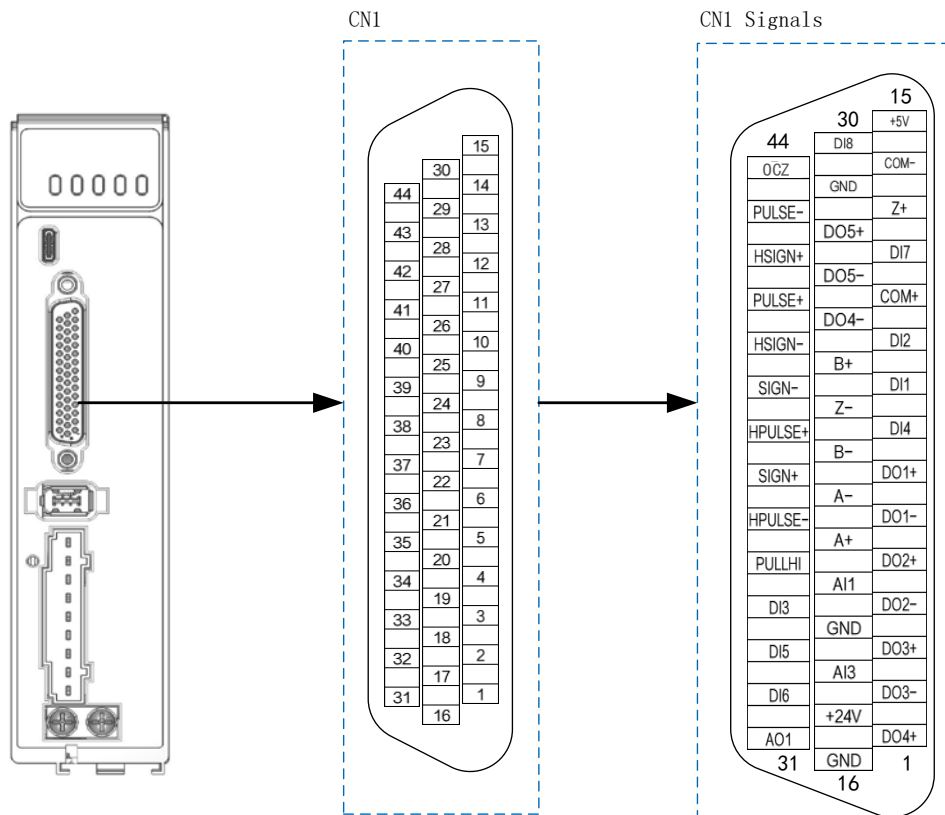

Function	Pin	Signal	Label	Description
Position command	41	PULSE+	Low speed pulse command input	Low speed pulse command input mode: • Differential (5V) • Single ended (24V)
	43	PULSE-	Low speed pulse command input	Low speed pulse and direction command input mode :
	37	SIGN+	Low speed direction command input	PULSE+ & PULSE-: 5V Differential (500KHz)
	39	SIGN-	Low speed direction command input	SIGN+ & SIGN- : 5V Differential (500KHz)
	35	PULLHI	Open collector 24V common input	PULLHI & PULSE-: 24V Single ended (200KHz)
	38	HPULSE+	High speed pulse command input	4MHz High speed pulse command input , 5V differential input
	36	HPULSE-	High speed pulse command input	
	42	HSIGN+	High speed direction command input	4MHz High speed direction command input , 5V differential input
	40	HSIGN-	High speed direction command input	

<b>Common</b>	17	+24V	Internal 24V power supply	24V internal power supply, range 20V~28V. Max. output current 200mA
	14	COM-		
<b>Digital inputs and outputs</b>	11	COM+	Common DI	Common DI
	9	DI1	POT	Positive limit
	10	DI2	NOT	Negative limit
	34	DI3	INH	Command pulse inhibition
	8	DI4	A-CLR	Alarm clearing
	33	DI5	SRV-ON	Servo enabled
	32	DI6	<i>Null</i>	-
	12	DI7	<i>Null</i>	-
	30	DI8	HOME-Switch	Homing switch (sensor)
	7	DO1+	SRDY+	Servo ready signal output
	6	DO1-	SRDY-	
	5	DO2+	INP1+	Positioning done signal output
	4	DO2-	INP1-	
	3	DO3+	BRK-OFF+	Holding brake output
	2	DO3-	BRK-OFF-	
	1	DO4+	ALARM+	Alarm output
	26	DO4-	ALARM-	
	28	DO5+	HOME-OK+	Homing done signal output
	27	DO5-	HOME-OK-	
<b>Analog input and output</b>	20	AI1	AI1	Velocity command or limit input(0~±10 V)
	18	AI2	AI2	Torque command or limit input (0~+10 V)
	31	AO1	AO1	Analogue output – Status monitoring
	19	GND	GND	Analogue ground
<b>Frequency divider output</b>	21	A+	Encoder A phase frequency divider output	Differential output, A/B phase quadrature frequency divided pulse output signal
	22	A-		
	25	B+	Encoder B phase frequency divider output	
	23	B-		
	13	Z+	Encoder Z phase frequency divider output	Differential output, motor Z phase signal output
	24	Z-		
	44	OCZ	Z-phase open collector output	Channel Z output (Open collector)
	29	GND	Z-phase open collector output signal ground	Channel Z output ground (Open collector)
<b>Common</b>	15	+5V	Internal 5V power supply	5V internal power supply. Max. output current 200mA
	16	GND		
	Frame		FG	Frame grounding

## CN2 - Motor Encoder

Port	Diagram	Pin	Signal	Description
CN2		1	VCC5V	Power supply 5V
		2	GND	Power supply ground
		3	BAT+	Battery positive terminal
		4	BAT-	Battery negative terminal
		5	SD+	SSI Data+
		6	SD-	SSI Data-
		Frame	PE	Shield grounding

## CN3/CN4 - RS485 Communication Port

Port	Diagram	Pin	Signal	Explain
CN3 CN4		1, 9	RDO+	RS485 Differential signal+
		2, 10	RDO -	RS485 Differential signal-
		3, 11	GND	Ground (RS485)
		4, 12	TXD+	RS485 Differential signal+
		5, 13	TXD-	RS485 Differential signal-
		6	VCC5V	Reserved, 5V positive (50mA)
		7, 15	GND	Ground
		8, 16	/	/
		Frame	PE	Shield grounding

## USB Type-C Tuning Port

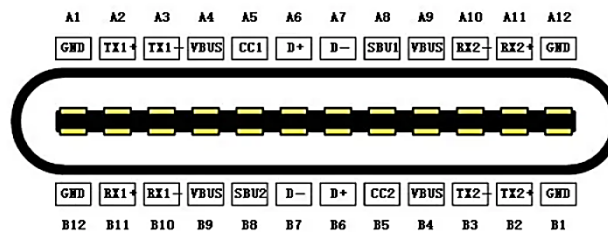

Port	Pin	Signal	Description
USB Type-C	A4, B4, A9, B9	VCC 5V	Power supply positive terminal 5V
	A12, B12, A1, B1	GND	Power supply negative terminal
	A6, B6	D+	USB data positive terminal
	A7, B7	D-	USB data negative terminal
	Frame	USB_GND	Ground through capacitor

# X1 Main power supply/Motor power supply

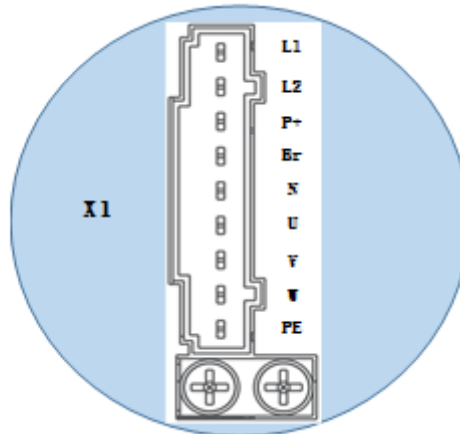

Port	Pin	Functions	Remarks
X1	L1	Single phase 220VAC, +10 ~ -15%, 50/60Hz	④ Optional isolation transformer
	L2		⑤ Do not connect to 380VAC directly to prevent damage to driver.
	P +	③ Internal DC bus positive terminal ④ External regenerative resistor P terminal	⑥ In case of serious interference, it is recommended to connect a line filter to main power supply;  <i>It is recommended to install a fuseless circuit breaker to cut off power supply in time when the driver fails.</i>
	Br	External regenerative resistor terminal	<i>Please refer to 2.10 Regenerative resistor selection and connections in User Manual</i>
	N		Please do not connect
	U	Motor U terminal	Please ensure proper wire connection on motor.
	V	Motor V terminal	
	W	Motor W terminal	
PE	Motor Protective Earth	Please ground PE of driver and motor together	



**ELM1/ELM2 Series Servo Motor**

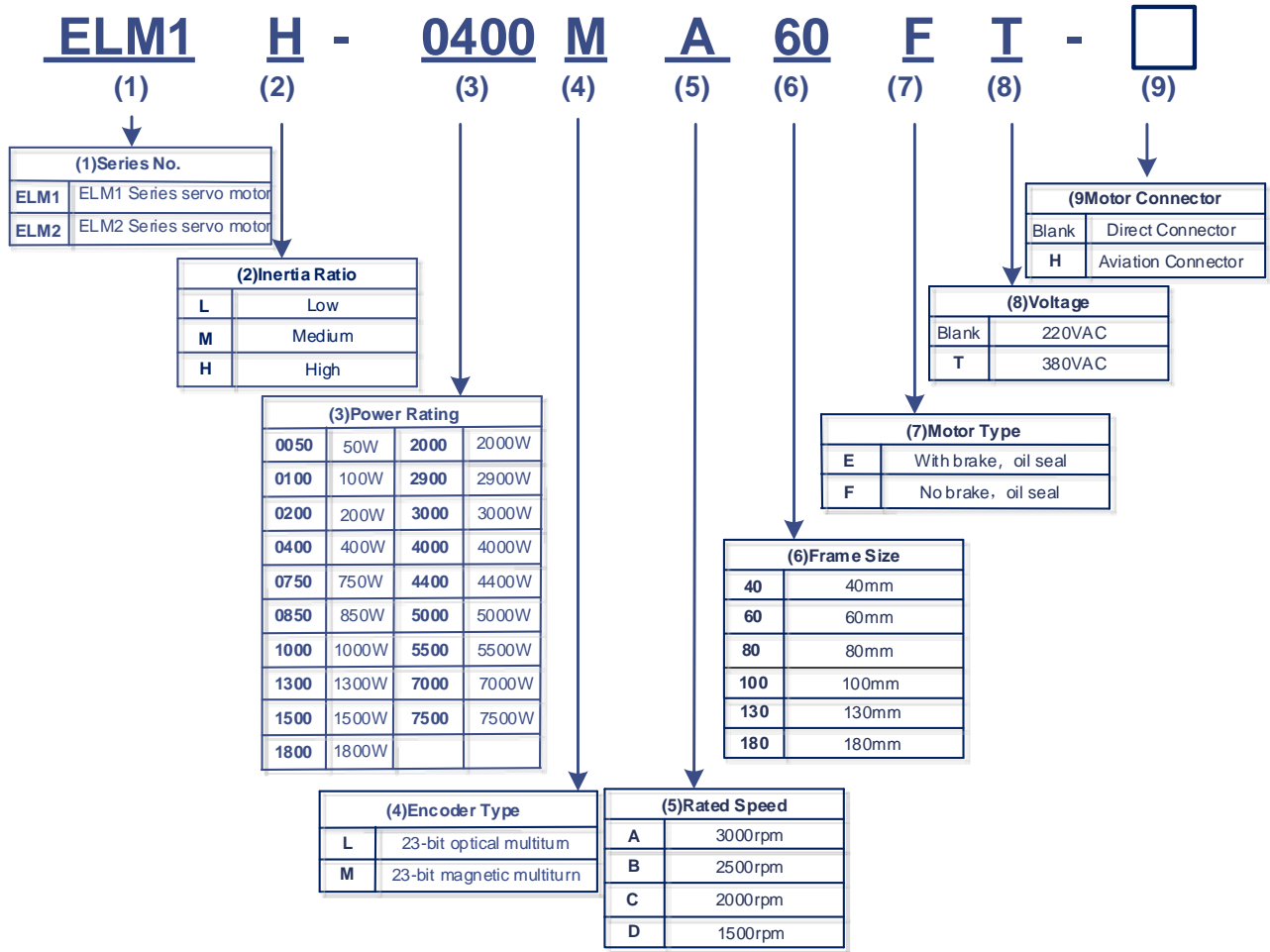

**Motors availability**

Power rating(W)		50	100	200	400	750	850	1000	1300	1500	1800	2000
Connector	Direct											
	Aviation											
Frame size (mm)	40											
	60											
	80											
	130											
Encoder 23-bit	Magnetic											
	Optical											
Rotational speed (rpm)	1500											
	2500											
	3000											

Ready soon!

\*All motor models come with optional holding brake.

\*\*The table will be updated from time to time as we released new and updated models.

# Cables

## Motors without holding brake

**Aviation connector (Frame size 80 or below) CABLE-RZ\*-HH2(V3.0)**

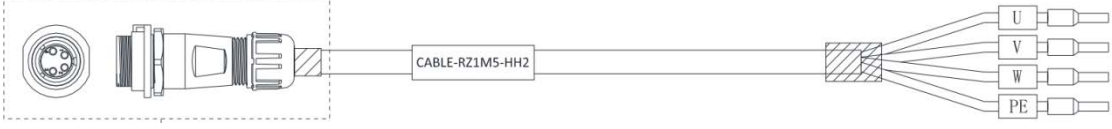

Motor side Driver side

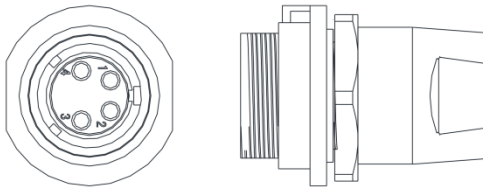
Motor cable pin	Pins		
 <p style="text-align: center;">Motor side</p>	Motor	Color	Driver
	1	Blue	U
	3	Black	V
	2	Red	W
	4	Yellow-green	PE

**Aviation connector (Frame size 130) CABLE-RZ\*H(V1.1/V2.0)**

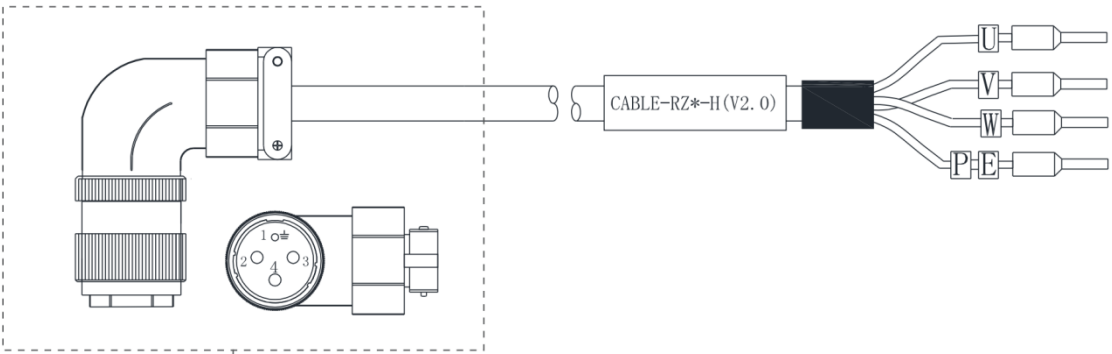

Motor side Driver side

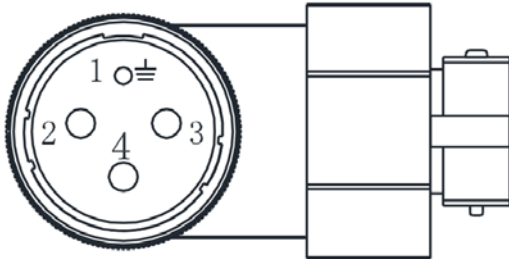
Motor cable pin	Pins		
 <p style="text-align: center;">Motor side</p>	Motor	Color	Driver
	1	Red	U
	3	Green	V
	2	Black	W
	4	Yellow	PE

Direct connector(Frame size 80 or below) CABLE-RZH\*M\*-114-TS without holding brake

Motor side Driver side

Driver cable pin	Pins															
	<table border="1" style="width: 100%; border-collapse: collapse;"> <thead> <tr> <th>Motor</th> <th>Color</th> <th>Driver</th> </tr> </thead> <tbody> <tr> <td style="text-align: center;">1</td> <td style="text-align: center;">Blue</td> <td style="text-align: center;">U</td> </tr> <tr> <td style="text-align: center;">2</td> <td style="text-align: center;">Black</td> <td style="text-align: center;">V</td> </tr> <tr> <td style="text-align: center;">3</td> <td style="text-align: center;">Red</td> <td style="text-align: center;">W</td> </tr> <tr> <td style="text-align: center;">4</td> <td style="text-align: center;">Yellow-green</td> <td style="text-align: center;">PE</td> </tr> </tbody> </table>	Motor	Color	Driver	1	Blue	U	2	Black	V	3	Red	W	4	Yellow-green	PE
Motor	Color	Driver														
1	Blue	U														
2	Black	V														
3	Red	W														
4	Yellow-green	PE														

**Motors with holding brake**

Aviation connector (Frame size 80 or below) CABLE-RZSH\*M\*-113-TS Winding cable with holding brake

Motor side Driver side

Motor cable pin	Pins																					
<p style="text-align: center;">Motor side</p>	<table border="1" style="width: 100%; border-collapse: collapse;"> <thead> <tr> <th>Motor</th> <th>Color</th> <th>Driver</th> </tr> </thead> <tbody> <tr> <td style="text-align: center;">1</td> <td style="text-align: center;">Blue</td> <td style="text-align: center;">U</td> </tr> <tr> <td style="text-align: center;">2</td> <td style="text-align: center;">Red</td> <td style="text-align: center;">W</td> </tr> <tr> <td style="text-align: center;">3</td> <td style="text-align: center;">Black</td> <td style="text-align: center;">V</td> </tr> <tr> <td style="text-align: center;">4</td> <td style="text-align: center;">Yellow-green</td> <td style="text-align: center;">PE</td> </tr> <tr> <td style="text-align: center;">5</td> <td style="text-align: center;">Black</td> <td style="text-align: center;">0V</td> </tr> <tr> <td style="text-align: center;">6</td> <td style="text-align: center;">Red</td> <td style="text-align: center;">24V</td> </tr> </tbody> </table>	Motor	Color	Driver	1	Blue	U	2	Red	W	3	Black	V	4	Yellow-green	PE	5	Black	0V	6	Red	24V
Motor	Color	Driver																				
1	Blue	U																				
2	Red	W																				
3	Black	V																				
4	Yellow-green	PE																				
5	Black	0V																				
6	Red	24V																				

**Direct connector CABLE-RZH\*M\*-114-TS Winding cable with holding brake**

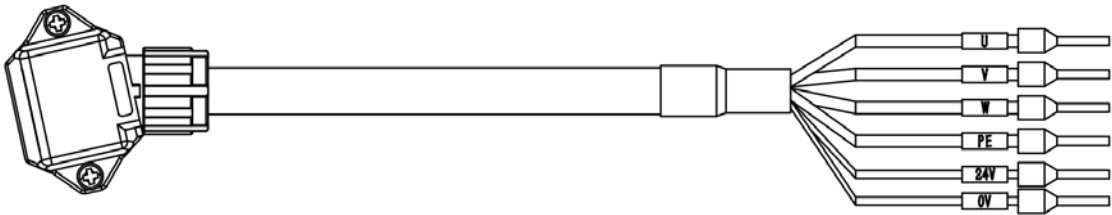

Motor side
Driver side

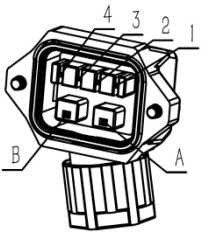
Motor cable pin	Pin		
			
	Motor	Color	Driver
	1	Blue	U
	2	Black	V
	3	Red	W
	4	Yellow-green	PE
	A	Black	0V
	B	Red	24V

**Encoder cable**

**Aviation connector (Frame size 80 or below) CABLE-7BM\*-HH2**

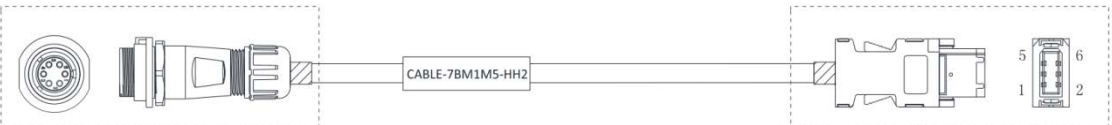

Motor side
Driver side

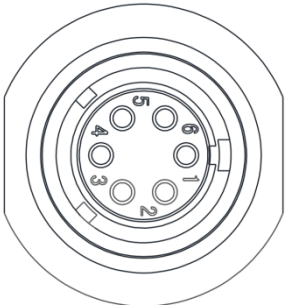
Motor cable pin	Pin		
			
Motor side	Motor	Driver	Signal
	1	Frame	Shielded
	2	1	+5V
	3	2	0V
	4	5	SD+
	5	6	SD-
	6	3	BAT+
	7	4	BAT-

Direct connector(Frame size 80 or below) CABLE-BMAH\*M\*-124-TS Absolute encoder

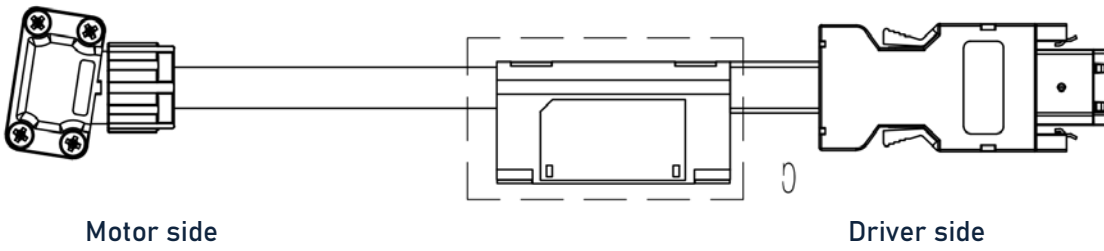

Motor cable pin	Pin																										
<p>Motor side</p>	<table border="1"> <thead> <tr> <th>Motor</th> <th>Driver</th> <th>Signal</th> </tr> </thead> <tbody> <tr> <td>1</td> <td>Frame</td> <td>Shielded</td> </tr> <tr> <td>2</td> <td>1</td> <td>+5V</td> </tr> <tr> <td>3</td> <td>2</td> <td>0V</td> </tr> <tr> <td>4</td> <td>5</td> <td>SD+</td> </tr> <tr> <td>5</td> <td>6</td> <td>SD-</td> </tr> <tr> <td>6</td> <td>3</td> <td>BAT+</td> </tr> <tr> <td>7</td> <td>4</td> <td>BAT-</td> </tr> </tbody> </table>	Motor	Driver	Signal	1	Frame	Shielded	2	1	+5V	3	2	0V	4	5	SD+	5	6	SD-	6	3	BAT+	7	4	BAT-		
Motor	Driver	Signal																									
1	Frame	Shielded																									
2	1	+5V																									
3	2	0V																									
4	5	SD+																									
5	6	SD-																									
6	3	BAT+																									
7	4	BAT-																									

Aviation connector (Frame size 130) CABLE-7BM\*HZ (V3.0)

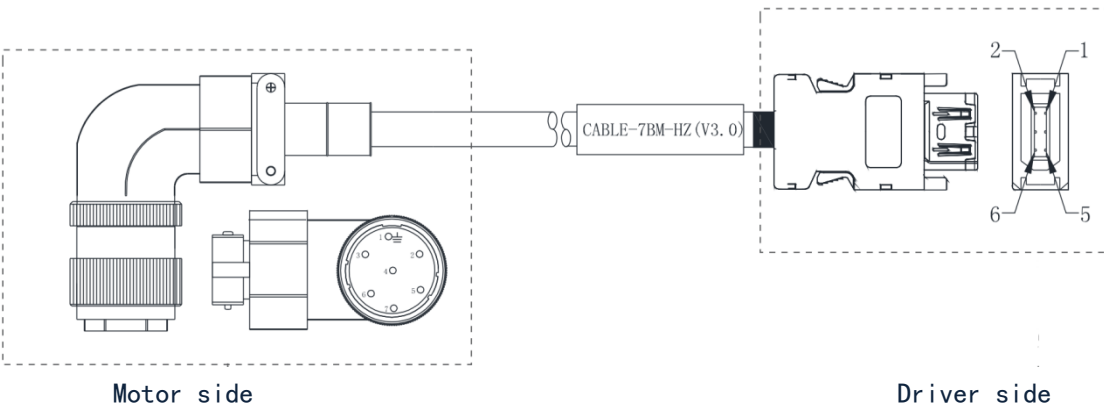

Motor cable pin	Pin																										
<p>Motor side</p>	<table border="1"> <thead> <tr> <th>Motor</th> <th>Driver</th> <th>Signal</th> </tr> </thead> <tbody> <tr> <td>1</td> <td>Frame</td> <td>Shielded</td> </tr> <tr> <td>2</td> <td>1</td> <td>+5V</td> </tr> <tr> <td>3</td> <td>2</td> <td>0V</td> </tr> <tr> <td>4</td> <td>5</td> <td>SD+</td> </tr> <tr> <td>5</td> <td>6</td> <td>SD-</td> </tr> <tr> <td>6</td> <td>3</td> <td>BAT+</td> </tr> <tr> <td>7</td> <td>4</td> <td>BAT-</td> </tr> </tbody> </table>	Motor	Driver	Signal	1	Frame	Shielded	2	1	+5V	3	2	0V	4	5	SD+	5	6	SD-	6	3	BAT+	7	4	BAT-		
Motor	Driver	Signal																									
1	Frame	Shielded																									
2	1	+5V																									
3	2	0V																									
4	5	SD+																									
5	6	SD-																									
6	3	BAT+																									
7	4	BAT-																									