

Parameter List – EtherCAT

Parameter Valid mode Description

P: Position control mode

V: Velocity control mode

T: Torque control mode

Servo drive parameter

Class	Label	EtherCAT Address	Panel display	Activation	Valid Mode		
[Class 0] Basic settings	Model-following bandwidth	2000h	PR_000	Immediate	P	V	T
	Control Mode Settings	2001h	PR_001	After restart	P	V	T
	Real time Auto Gain Adjusting	2002h	PR_002	Immediate	P	V	T
	Real time auto stiffness adjusting	2003h	PR_003	Immediate	P	V	T
	Inertia ratio	2004h	PR_004	Immediate	P	V	T
	Command polarity inversion	2006h	PR_006	After restart	P		
	Probe signal polarity settings/Command pulse input mode settings	2007h	PR_007	After restart	P		
	Command pulse counts per revolution	2008h	PR_008	After restart	P		
	Encoder pulse output per revolution	2011	PR_011	After restart	P	V	T
	Pulse output logic inversion	2012	PR_012	After restart	P	V	T
	1 st Torque Limit	2013h	PR_013	Immediate	P	V	T
	Excessive Position Deviation Settings	2014h	PR_014	Immediate	P		
	Absolute Encoder settings	2015h	PR_015	After restart	P	V	T
	Regenerative resistance	2016h	PR_016	Immediate	P	V	T
	Regenerative resistor power rating	2017h	PR_017	Immediate	P	V	T
	Friction compensation setting	2019h	PR_019	Immediate	P	V	T
	EtherCAT slave ID	2023h	PR_023	After restart	P	V	T
	Source of slave ID	2024h	PR_024	After restart	P	V	T
	Synchronous compensation time 1	2025h	PR_025	After restart	P		
	Synchronous compensation time 2	2026h	PR_026	After restart	P		
Synchronization mode command delay cycle counts	2027h	PR_027	After restart	P			

Class	Label	EtherCAT Address	Panel display	Activation	Valid Mode		
	CSP mode safe self-running position setting	2028h	PR_028	Immediate	P		
[Class 1] Gain adjustments	1 st position loop gain	2100h	PR_100	Immediate	P		
	1 st velocity loop gain	2101h	PR_101	Immediate	P	V	T
	1 st Integral Time Constant of Velocity Loop	2102h	PR_102	Immediate	P	V	T
	1 st velocity detection filter	2103h	PR_103	Immediate	P	V	T
	1 st Torque Filter Time Constant	2104h	PR_104	Immediate	P	V	T
	2 nd Position Loop Gain	2105h	PR_105	Immediate	P		
	2 nd velocity loop gain	2106h	PR_106	Immediate	P	V	T
	2 nd Integral Time Constant of Velocity Loop	2107h	PR_107	Immediate	P	V	T
	2 nd velocity detection filter	2108h	PR_108	Immediate	P	V	T
	2 nd Torque Filter Time Constant	2109h	PR_109	Immediate	P	V	T
	Velocity feed forward gain	2110h	PR_110	Immediate	P		
	Velocity feed forward filter time constant	2111h	PR_111	Immediate	P		
	Torque feed forward gain	2112h	PR_112	Immediate	P	V	
	Torque feed forward filter time constant	2113h	PR_113	Immediate	P	V	
	Position control gain switching mode	2115h	PR_115	Immediate	P		
	Position control gain switching level	2117h	PR_117	Immediate	P		
	Hysteresis at position control switching	2118h	PR_118	Immediate	P		
	Position gain switching time	2119h	PR_119	Immediate	P		
	Position command pulse filter time	2135h	PR_135	Immediate	P		
	[Class 2] Vibration suppression	Adaptive filtering mode settings	2200h	PR_200	Immediate	P	V
1 st notch frequency		2201h	PR_201	Immediate	P	V	T
1 st notch bandwidth selection		2202h	PR_202	Immediate	P	V	T
1 st notch depth selection		2203h	PR_203	Immediate	P	V	T
2 nd notch frequency		2204h	PR_204	Immediate	P	V	T
2 nd notch bandwidth selection		2205h	PR_205	Immediate	P	V	T
2 nd notch depth selection		2206h	PR_206	Immediate	P	V	T
3 rd notch frequency		2207h	PR_207	Immediate	P	V	T
3 rd notch bandwidth selection		2208h	PR_208	Immediate	P	V	T
3 rd notch depth selection		2209h	PR_209	Immediate	P	V	T

Class	Label	EtherCAT Address	Panel display	Activation	Valid Mode		
					P	V	T
	1 st damping frequency	2214h	PR_214	Immediate	P		
	2 nd damping frequency	2216h	PR_216	Immediate	P		
	Position command smoothing filter	2222h	PR_222	Keep stop	P		
	Position command FIR filter	2223h	PR_223	Disable	P		
	5 th resonant frequency	2231h	PR_231	Immediate	P	V	T
	5 th resonant Q value	2232h	PR_232	Immediate	P	V	T
	5 th anti-resonant frequency	2233h	PR_233	Immediate	P	V	T
	5 th anti-resonant Q value	2234h	PR_234	Immediate	P	V	T
	6 th resonant frequency	2235h	PR_235	Immediate	P	V	T
	6 th resonant Q value	2236h	PR_236	Immediate	P	V	T
	6 th anti-resonant frequency	2237h	PR_237	Immediate	P	V	T
	6 th anti-resonant Q value	2238h	PR_238	Immediate	P	V	T
[Class 3] Velocity/Torque Control	Internal/External settings of velocity settings	2300h	PR_300	Immediate		V	
	Velocity command rotational direction selection	2301h	PR_301	Immediate		V	T
	Velocity command input gain	2302h	PR_302	Immediate		V	
	Velocity command input inversion	2303h	PR_303	Immediate		V	
	1 st speed of velocity setting	2304h	PR_304	Immediate		V	
	2 nd speed of velocity setting	2305h	PR_305	Immediate		V	
	3 rd speed of velocity setting	2306h	PR_306	Immediate		V	
	4 th speed of velocity setting	2307h	PR_307	Immediate		V	
	5 th speed of velocity setting	2308h	PR_308	Immediate		V	
	6 th speed of velocity setting	2309h	PR_309	Immediate		V	
	7 th speed of velocity setting	2310h	PR_310	Immediate		V	
	8 th speed of velocity setting	2311h	PR_311	Immediate		V	
	Acceleration time	2312h	PR_312	Immediate		V	
	Deceleration time settings	2313h	PR_313	Immediate		V	
Sigmoid acceleration/deceleration settings	2314h	PR_314	Disable		V		

Class	Label	EtherCAT Address	Panel display	Activation	Valid Mode		
						V	T
	Zero speed clamp function selection	2315h	PR_315	Immediate		V	
	Zero speed clamp level	2316h	PR_316	Immediate		V	
	Internal/External settings of torque	2317h	PR_317	Immediate			T
	Torque command direction selection	2318h	PR_318	Immediate			T
	Velocity limit value in torque mode	2321h	PR_321	Immediate			T
	Torque limit value in torque mode	2322h	PR_322	Immediate	P	V	T
	Zero speed clamp static time	2323h	PR_323	Immediate	P	V	T
	Maximum motor rotational velocity	2324h	PR_324	Immediate	P	V	T
[Class 4] I/O interfaces	Input selection DI1	2400h	PR_400	Immediate	P	V	T
	Input selection DI2	2401h	PR_401	Immediate	P	V	T
	Input selection DI3	2402h	PR_402	Immediate	P	V	T
	Input selection DI4	2403h	PR_403	Immediate	P	V	T
	Output selection DO1	2410h	PR_410	Immediate	P	V	T
	Output selection DO2	2411h	PR_411	Immediate	P	V	T
	Output selection DO3	2412h	PR_412	Immediate	P	V	T
	Positioning complete range	2431h	PR_431	Immediate	P		
	Positioning complete output setting	2432h	PR_432	Immediate	P		
	INP positioning delay time	2433h	PR_433	Immediate	P		
	Zero speed	2434h	PR_434	Immediate	P	V	T
	Velocity coincidence range	2435h	PR_435	Immediate		V	
	Arrival velocity	2436h	PR_436	Immediate		V	
	Motor power-off delay time	2437h	PR_437	Immediate	P	V	T
	Delay time for holding brake release	2438h	PR_438	Immediate	P	V	T
	Holding brake activation speed	2439h	PR_439	Immediate	P	V	T
	Emergency stop function	2443h	PR_443	Immediate	P	V	T
	2 nd pulse count per revolution	2500h	PR_500	After restart	P		
	2 nd Command frequency divider/multiplier numerator	2501h	PR_501	After restart	P		
	2 nd Command frequency divider/multiplier denominator	2502h	PR_502	After restart	P		
	Driver prohibition input settings	2504h	PR_504	Immediate	P	V	T

Class	Label	EtherCAT Address	Panel display	Activation	Valid Mode		
[Class 5] Extension settings	Servo-off mode	2506h	PR_506	After restart	P	V	T
	Main power-off detection time	2509h	PR_509	Immediate	P	V	T
	Servo-off due to alarm mode	2510h	PR_510	After restart	P	V	T
	Servo braking torque setting	2511h	PR_511	Immediate	P	V	T
	Overload level setting	2512h	PR_512	Immediate	P	V	T
	Overspeed level settings	2513h	PR_513	Immediate	P	V	T
	I/O digital filter	2515h	PR_515	Immediate	P	V	T
	Counter clearing input mode	2517h	PR_517	Immediate	P		
	Position unit settings	2520h	PR_520	Disable	P		
	Torque limit selection	2521h	PR_521	Immediate	P	V	T
	2 nd torque limit	2522h	PR_522	Immediate	P	V	T
	Positive torque warning threshold	2523h	PR_523	Immediate	P	V	T
	Negative torque warning threshold	2524h	PR_524	Immediate	P	V	T
	LED initial status	2528h	PR_528	After restart	P	V	T
	Max. command pulse input frequency	2532h	PR_532	Immediate	P		
[Class 6] Other settings	Encoder zero position compensation	2601h	PR_601	After restart	P	V	T
	JOG trial run velocity command	2604h	PR_604	Immediate	P		
	Position 3 rd gain valid time	2605h	PR_605	Immediate	P		
	Position 3 rd gain scale factor	2606h	PR_606	Immediate	P		
	Torque command additional value	2607h	PR_607	Immediate	P	V	T
	Positive direction torque compensation value	2608h	PR_608	Immediate	P	V	T
	Negative direction torque compensation value	2609h	PR_609	Immediate	P	V	T
	Current response settings	2611h	PR_611	Immediate	P	V	T
	Max. time to stop after disabling	2614h	PR_614	Immediate	P	V	T
	Trial run distance	2620h	PR_620	Immediate	P		
	Trial run waiting time	2621h	PR_621	Immediate	P		
	No. of trial run cycles	2622h	PR_622	Immediate	P		
	Trial run acceleration	2625h	PR_625	Immediate	P	V	
	Velocity observer gain	2628h	PR_628	Immediate	P	V	T
	Velocity observer bandwidth	2629h	PR_629	Immediate	P	V	T
Frame error window time	2634h	PR_634	Immediate	P	V	T	

Class	Label	EtherCAT Address	Panel display	Activation	Valid Mode		
					P	V	T
	Frame error window	2635h	PR_635	Immediate	P	V	T
	Absolute value rotation mode denominator setting	2654h	PR_654	After restart	P		
	Blocked rotor alarm torque threshold	2656h	PR_656	Immediate	P	V	T
	Blocked rotor alarm delay time	2657h	PR_657	Immediate	P	V	T
	Homing mode position threshold	2659h	PR_659	Immediate	P	V	T
	Z signal holding time	2661h	PR_661	Immediate	P	V	T
	Absolute multiturn data upper limit	2663h	PR_663	After restart	P	V	T

Manufacturer parameter

Index	Sub index	Label	Unit	Default	Min	Max	Details
5004	01	RPDO length		8	0	64	
	02	TPDO length		17	0	64	
	03	The number of RPDO		1	0	4	
	04	The number of TPDO		1	0	2	
	05	Sync0 Watchdog counter		0	0	65535	
	06	Reserved			0	65535	
	07	Sync0 Watchdog limit		4	0	65535	73B alarm threshold value, set to zero shield
	08	Sync0 Drift watchdog counter		0	0	65535	
	09	Sync0 Drift watchdog limit		4	0	65535	73C alarm threshold value, set to zero shield
	0A	SM2 watchdog counter		0	0	65535	
	0B	SM2 Watchdog limit		4	0	65535	73A alarm threshold value, set to zero shield
	0C	Application layer SM2/Sync0 watchdog counter		0			
	0D	Application layer SM2/Sync0 watchdog limit		4			
	0E	Reserved			0	500	
	0F	Time interval between SM2 and Sync0	ns	0	0	100000000	832h Alarm detection

5006	00	Synchronous alarm setting			0xFFFF F	0	0xFFFF F	Bit0:818h Alarm enable switch Bit1: 819h Bit2: 81Ah Bit3: 824h Bit4: 825h Bit5: Reserved Bit6: Reserved Bit7: 82Ch Bit8: 82Dh Bit9: 832h Bit10~15: Reserved Notes: 0 invalid; 1 valid																				
5010	00	PDO watchdog overtime	ms	0	0	60000		0: invalid; > 0: valid; Unit: ms; Such as RPDO timeout alarm 818h, TPDO timeout alarm 819h																				
5012	04	Homing setting	-	5				Bit0: Abnormal signal protection 0: invalid; 1: valid Bit1: pull back if overtravel while final stop 0: invalid; 1: valid Bit2/Bit3: <table border="1"> <thead> <tr> <th>Bit2</th> <th>Bit3</th> <th>Positive limit position</th> <th>Negative limit position</th> <th>Feedback after the homing process</th> </tr> </thead> <tbody> <tr> <td>0</td> <td>0</td> <td>607D-02+ 607C</td> <td>607D-01 + 607C</td> <td>6064 = 607C</td> </tr> <tr> <td>0</td> <td>1</td> <td>607D-02- 607C</td> <td>607D-01 - 607C</td> <td>6064 = -607C</td> </tr> <tr> <td>1</td> <td>-</td> <td>607D-02</td> <td>607D-01</td> <td>6064 = 0</td> </tr> </tbody> </table> Bit4: Deal with Overtravel between the high speed and low speed during homing process 0: Homing process error (set 6041h bit13=1); 1: As normal, continue homing process	Bit2	Bit3	Positive limit position	Negative limit position	Feedback after the homing process	0	0	607D-02+ 607C	607D-01 + 607C	6064 = 607C	0	1	607D-02- 607C	607D-01 - 607C	6064 = -607C	1	-	607D-02	607D-01	6064 = 0
Bit2	Bit3	Positive limit position	Negative limit position	Feedback after the homing process																								
0	0	607D-02+ 607C	607D-01 + 607C	6064 = 607C																								
0	1	607D-02- 607C	607D-01 - 607C	6064 = -607C																								
1	-	607D-02	607D-01	6064 = 0																								
5400	01	Set synchronization cycle minimum value	us	250	125	1000																						
5400	02	Set synchronization cycle maximum value	us	10000	4000	20000																						
5500	01	Absolute encoder	r	-	-	-	-																					

		multiturn number					
	02	Encoder single turn position	Pulse	-	-	-	-
	03	Encoder feedback position 32 bit low	Pulse	-	-	-	-
	04	Encoder feedback position 32 bit high	Pulse	-	-	-	-
	05	The actual mechanical position 32 bit low	Unit	-	-	-	-
	06	The actual mechanical position 32 bit high	Unit	-	-	-	-
	07	Number of encoder communication exceptions		-	-	-	-
5501	01	Motor Speed	r/min	-	-	-	-
	02	Speed of position command	r/min	-	-	-	-
	03	Speed command	r/min	-	-	-	-
	04	Actual torque	0.1%	-	-	-	-
	05	Torque command	0.1%	-	-	-	-
	06	Relative position error	Pulse	-	-	-	-
	07	Internal position command	Pulse	-	-	-	-
	08	Overload ratio	0.1%	-	-	-	-
	09	Discharge load rate	0.1%	-	-	-	-
	0A	Inertia ratio	%	-	-	-	-
	0B	Actual positive torque limit value	0.1%	-	-	-	-
	0C	Actual negative torque limit value	0.1%	-	-	-	-
	0D	U phase current detect value	0.1%	-	-	-	-
	0E	W phase current detect value	0.1%	-	-	-	-
5502	01	DI input signal	-	-	-	-	-
	02	SO output signal	-	-	-	-	-
	03	Reserved	-	-	-	-	-
	04	Reserved	-	-	-	-	-
	05	Bus voltage	V	-	-	-	-
	06	Temperature	°C	-	-	-	-
	07	Power on time	S	-	-	-	-

Motion parameter starting with object dictionary 6000

Index	Sub-index	Label	Unit	Default	Min	Max
603F	0	Error code	-	0x0	0x0	0xFFFF
6040	0	Control word	-	0x0	0x0	0xFFFF
6041	0	Status word	-	0x0	0x0	0xFFFF
605A	0	Quick stop option code	-	2	0	7
605B	0	Motor deceleration-stopping mode selection	-	0	0	1
605C	0	Axis disabled-stopping mode selection	-	0	0	1
605D	0	Pause-stopping mode selection	-	1	1	3
605E	0	Alarm - stopping mode selection	-	0	0	2
6060	0	Operation mode selection	-	8	1	11
6061	0	Operation mode display	-	0	0	10
6062	0	Position command	Command unit	0	- 2147483 648	2147483 647
6063	0	Actual internal position	Encoder unit	0	- 2147483 648	2147483 647
6064	0	Actual position feedback	Command unit	-	- 2147483 648	2147483 647
6065	0	Position deviation window	Command unit	30000	0	2147483 647
6066	0	Position deviation detection time	ms	10	0	65535
6067	0	Position window	Command unit/s	0	0	214748 3647
6068	0	Position window time	ms	0	0	65535
606B	0	Internal command velocity	Command unit/s	0	- 2147483 648	2147483 647
606C	0	Velocity feedback	Command unit/s	0	- 2147483 648	2147483 647
606D	0	Velocity window	Command unit /s	10	0	65535
606E	0	Velocity window time	ms	0	0	65535
606F	0	Zero-speed threshold	Command unit/s	10	0	65535
6071	0	Target torque	0.001	0	-32768	32767
6072	0	Maximum torque	0.001	3000	0	65535
6073	0	Maximum current	0.001	3000	-	65535
6074	0	Internal command torque	0.001	0	-32768	32767
6075	0	Motor current rating	mA	3000	0	2147483

						647
6077	0	Actual torque	0.1%	0	-32768	32767
6079	0	DC bus voltage	mV	0	0	2147483 647
607A	0	Target position	Command unit	0	- 2147483 648	2147483 647
607C	0	Homing position offset	Command unit	0	- 2147483 648	2147483 647
607D	1	Min. software limit	Command unit	0	- 2147483 648	2147483 647
	2	Max. software limit	Command unit	0	- 2147483 648	2147483 647
607E	0	Motor rotational direction	-	0x0	0x0	0xFF
607F	0	Maximum protocol velocity	Command unit /s	214748 3647	0	2147483 647
6080	0	Maximum motor velocity	r/min	6000	0	2147483 647
6081	0	Protocol velocity	Command unit /s	10000	0	2147483 647
6083	0	Protocol acceleration	Command unit /s ²	10000	1	2147483 647
6084	0	Protocol deceleration	Command unit /s ²	10000	1	2147483 647
6085	0	Emergency stop deceleration	Command unit /s ²	100000 00	1	2147483 647
6087	0	Torque slope	0.001/s	5000	1	2147483 647
608F	1	Encoder resolution	Encoder unit	0	0	2147483 647
6091	1	Electronic gear ratio numerator	r	1	1	2147483 647
	2	Electronic gear ratio denominator	r	1	1	2147483 647
6092	1	Number of pulses per rotation	Command unit/r	10000	1	2147483 647
6098	0	Homing method	-	19	-6	37
6099	1	High velocity homing	Command unit /s	10000	0	2147483 647
	2	Low velocity homing	Command unit /s	5000	0	2147483 647
609A	0	Homing acceleration /deceleration	Command unit /s ²	50000 0	1	2147483 647
60B0	0	Position feedforward	Command unit	0	- 2147483 648	2147483 647
60B1	0	Velocity feedforward	Command	0	-	2147483

			unit /s		2147483 648	647
60B2	0	Torque feedforward	0.001	0	-32768	32767
60B8	0	Probe function	-	0x0	0x0	0xFFFF
60B9	0	Probe status	-	0x0	0x0	0xFFFF
60BA	0	Probe 1 rising edge captured position	Command unit	0	- 2147483 648	2147483 647
60BB	0	Probe 1 falling edge captured position	Command unit	0	- 2147483 648	2147483 647
60BC	0	Probe 2 rising edge captured position	Command unit	0	- 2147483 648	2147483 647
60BD	0	Probe 2 falling edge captured position	Command unit	0	- 2147483 648	2147483 647
60C5	0	Protocol maximum acceleration	Command unit /s ²	100000 000	1	2147483 647
60C6	0	Protocol maximum deceleration	Command unit /s ²	100000 000	1	2147483 647
60D5	0	Probe 1 rising edge captured count(s)	-	0	0	65535
60D6	0	Probe 1 falling edge captured count(s)	-	0	0	65535
60D7	0	Probe 2 rising edge captured count(s)	-	0	0	65535
60D8	0	Probe 2 falling edge captured count(s)	-	0	0	65535
60E0	0	Max. torque in positive direction	0.001	3000	0	65535
60E1	0	Max. torque in negative direction	0.001	3000	0	65535
60F4	0	Actual following error	Command unit	0	- 2147483 648	2147483 647
60FA	0	Position loop velocity output	Command unit /s	0	- 2147483 648	2147483 647
60FC	0	Internal command position	Encoder unit	0	- 2147483 648	2147483 647
60FD	0	Input status	-	0x0	0x0	0x7FFFF FFF
60FE	1	Output valid	-	0x0	0x0	0x7FFFF FFF
	2	Output enabled	-	0x0	0x0	0x7FFFF FFF
60FF	0	Target velocity	Command unit /s	0	- 2147483	2147483 647

					648	
6502	0	Supported operation modes	-	0x0	0x0	0x7FFFF FFF

Parameter Description

Parameter valid under following modes

P: Position control mode

V: Velocity control mode

T: Torque control mode

【Class 0】 Basic Settings

Pr0.00	Label	Model-following bandwidth			Valid Mode	P	V	T										
	Range	0~5000	Unit	0.1Hz	Default	1	Index	2000h										
	Activation	Immediate																
<p>Model-following bandwidth, also known as model-following control (MFC), is used to control the position loop to improve the responsiveness to commands, speed up positioning time and reduce following error. The effect is obvious especially in low and medium mechanical stiffness.</p> <table border="1"> <thead> <tr> <th>Value</th> <th>Explanation</th> </tr> </thead> <tbody> <tr> <td>0</td> <td>Disable the function.</td> </tr> <tr> <td>1</td> <td>Enable the function to set bandwidth automatically, recommended for most applications. Pr0.00=Pr1.01</td> </tr> <tr> <td>2</td> <td>Reserved</td> </tr> <tr> <td>3-9</td> <td>Invalid</td> </tr> </tbody> </table> <p>Pr0.00>9: Model-following bandwidth value set by Pr0.00. 10<Pr0.00<5000: Specifies the bandwidth. <i>*Recommended settings for belt application: 30<Pr0.00<100.</i></p>									Value	Explanation	0	Disable the function.	1	Enable the function to set bandwidth automatically, recommended for most applications. Pr0.00=Pr1.01	2	Reserved	3-9	Invalid
Value	Explanation																	
0	Disable the function.																	
1	Enable the function to set bandwidth automatically, recommended for most applications. Pr0.00=Pr1.01																	
2	Reserved																	
3-9	Invalid																	

Pr0.01	Label	Control Mode Settings			Valid Mode	P	V	T									
	Range	0~9	Unit	—	Default	9	Index	2001h									
	Activation	After restart															
<p>Set value to use following control modes:</p> <table border="1"> <thead> <tr> <th>Value</th> <th>Content</th> <th>Details</th> </tr> </thead> <tbody> <tr> <td>0-8</td> <td>Reserved</td> <td>Reserved</td> </tr> <tr> <td>9</td> <td>EtherCAT mode</td> <td>PP/PV/PT/HM/CSP/CSV/CST</td> </tr> </tbody> </table>									Value	Content	Details	0-8	Reserved	Reserved	9	EtherCAT mode	PP/PV/PT/HM/CSP/CSV/CST
Value	Content	Details															
0-8	Reserved	Reserved															
9	EtherCAT mode	PP/PV/PT/HM/CSP/CSV/CST															

Pr0.02	Label	Real time Auto Gain Adjusting			Valid Mode	P	V	T
	Range	0x0~0xFFFF	Unit	—	Default	0x001	Index	2002h
	Activation	Immediate						

Set up the mode of the real time auto gain adjusting.

Data bits	Category	Settings	Application
0x00_	Motion setting mode	Used to set motion setting mode, which can be selected according to the motion characteristics or setting requirements. Generally, it is recommended to select mode 1 with good generality when there is no special requirement, mode 2 when rapid positioning is needed. If mode 1 and mode 2 cannot meet the requirements, please choose mode 0.	
		0:Manual	Pr0.03 invalid. Gain value must be adjusted manually and accordingly.
		1:Standard	Pr0.03 valid. Quick gain adjusting can be achieved by changing Pr0.03 stiffness value. Gain switching is not used in this mode, suitable for applications with requirements for stability.
		2:Positioning	Pr0.03 valid. Quick gain adjusting can be achieved by changing Pr0.03 stiffness value. This mode is suitable for applications requiring quick positioning. Not recommended for load mounted vertical to ground, or please compensate for the load using Pr6.07
0x0_0	Load type setting	Used to select the load type, choose according to load-inertia ratio and mechanical structure.	
		0: Rigid structure	This mode prioritizes system responsiveness. Use this mode when there is a relatively rigid structure with low load inertia. Typical application including directly connected high-precision gearbox, lead screw, gears, etc.
		1:High inertia	For applications with higher load inertia (10 times or above), gain settings take into account both machine stability and responsiveness. Not recommended to set stiffness above 15 for high load inertia.
		2: Flexible structure	This mode prioritizes system stability. Use this mode when there is low rigidity structure with high load inertia. Typical applications included belts and chains.
0x_00	reserved		

The setting type combination is a hexadecimal standard, as follows:

Setting type combination	Application type
0X000	Rigid structure Manual
0X001	Rigid structure +Standard
0X002	Rigid structure +Positioning
0X010	High inertia + Manual
0X011	High inertia + Standard
0X012	High inertia + Positioning
0X020	Flexible structure + Manual
0X021	Flexible structure +Standard
0X022	Flexible structure +Positioning

Pr0.03	Label	Real time auto stiffness adjusting			Mode	P	V	T
	Range	50 ~ 81	Unit	—	Default	70	Index	2003h
	Activation	Immediate						

Valid when Pr0.03 = 1,2

Low ———> Mechanical stiffness ———> High

Low ———> Servo gain ———> High

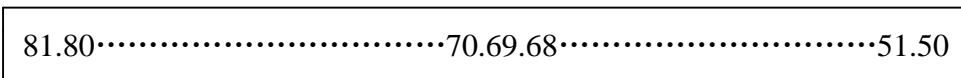

Low ———> Responsiveness ———> High

Lower values ensure better system responsiveness and mechanical stiffness but machine vibration might occur, please set accordingly.

Pr0.04	Label	Inertia ratio			Mode	P	V	T
	Range	0~2000 0	Unit	%	Default	250	Index	2004h
	Activation	Immediate						

$$\text{Pr0.04} = (\text{load inertia} / \text{motor rotational inertia}) \times 100\%$$

Set inertia ratio according to actual load inertia. When both are uniform, actual motor velocity loop responsiveness and gain settings will be consistent. If inertia ratio is greater than actual value, velocity loop gain settings will be higher and vice versa.

Pr0.06	Label	Command polarity inversion			Mode	P		
	Range	0 ~ 1	Unit	—	Default	0	Index	2006h
	Activation	After restart						
Used to change the rotational direction of the motor.								
Set value		Details						
0		Polarity of the command is not inverted. The direction of rotation is consistent with the polarity of command.						
1		Polarity of command is inverted. The direction of rotation is opposite to the polarity of command.						
Note: Rotational direction of the motor is recommended to be set through object dictionary 607E. However, Pr0.06 has higher priority than object dictionary 607E. 607E only takes effect when Pr0.06 = 0.								

Pr0.07	Label	Probe signal polarity settings/Command pulse input mode settings			Mode	P		
	Range	0 ~ 3	Unit	—	Default	3	Index	2007h
	Activation	After restart						
Probe signal polarity settings take effect when Pr0.01 = 9								
Set value		Details						
0		Probe 1 & 2 polarity inversion						
1		Probe 2 polarity inversion						
2		Probe 1 polarity inversion						
3		No polarity inversion for probe 1 & 2						

If Pr0.01 ≠ 9, Pr0.07 = Command pulse input mode settings.

Command pulse input

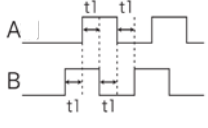
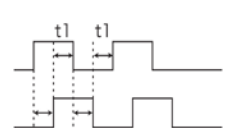
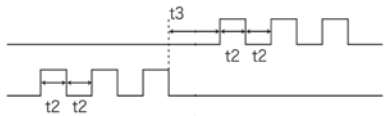
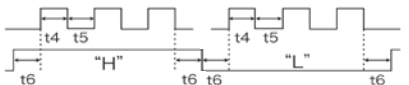
Command Polarity inversion (Pr0.06)	Command pulse input mode settings (Pr0.07)	Command Pulse Mode	Positive signal	Negative signal
【0】	0 or 2	90°phase difference 2 phase pulse (Phase A+ Phase B)		
	1	CW pulse sequence + CCW pulse sequence		
	【3】	Pulse sequence + Directional symbol		

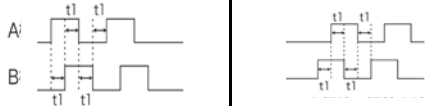
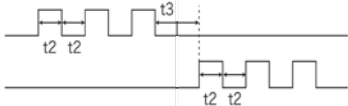
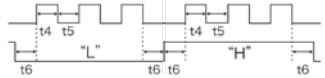
1	0 or 2	90°phase difference 2 phase pulse (Phase A + Phase B)	
	1	CW pulse sequence + CCW pulse sequence	
	□3	Pulse sequence + Directional symbol	

Command pulse input signal max. frequency and min. duration needed

Command pulse input interface		Max. Frequency	Min. duration needed (μs)					
			t1	t2	t3	t4	t5	t6
Pulse sequence interface	Differential drive	500 kHz	2	1	1	1	1	1
	Open collector	200 kHz	5	2.5	2.5	2.5	2.5	2.5















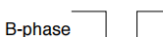
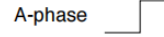
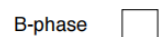

Please set >0.1μs for the duration between rising and falling edge of command pulse input signal.

1 revolution with 2500 pulses 2-phase pulse input when Pr0.07=0 or 2, Pr0.08 = 10000;

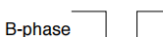
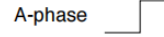
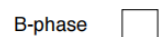
1 revolution with 10000 pulses 1-phase pulse input when Pr0.07=1 or 3, Pr0.08 = 10000

Pr0.08	Label	Command pulse counts per revolution			Mode	P		
	Range	0~8388608	Unit	P-	Default	0	Index	2008h
	Activation	After restart						
Pulses per revolution can be set using object dictionary 608F, 6091, 6092. However, Pr0.08 has higher priority.								

Pr0.11	Label	Encoder pulse output per revolution			Mode	P	V	T
	Range	0~65535	Unit	P/r	Default	2500	Index	2011
	Activation	After restart						
Including rising and falling edge of phase A and B, so encoder actual differential output pulse count = Pr0.011 x 4 Please make sure: Motor rotational speed x Pr0.11 x 4 ≤ 1MHz. If exceeds, alarm Er280 might occur.								

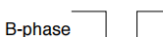
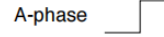
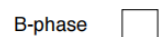
Pr0.12	Label	Pulse output logic inversion			Mode	P	V	T												
	Range	0~1	Unit	-	Default	0	Index	2012												
	Activation	After restart																		
<p>To set phase B logic and output source from encoder pulse output.</p> <p>Pulse output logic inversion</p> <table border="1"> <thead> <tr> <th>Pr0.12</th> <th>Phase B logic</th> <th>CW direction</th> <th>CCW direction</th> </tr> </thead> <tbody> <tr> <td>[0]</td> <td>Not inverted</td> <td> A-phase  B-phase  </td> <td> A-phase  B-phase  </td> </tr> <tr> <td>[1]</td> <td>Inverted</td> <td> A-phase  B-phase  </td> <td> A-phase  B-phase  </td> </tr> </tbody> </table>									Pr0.12	Phase B logic	CW direction	CCW direction	[0]	Not inverted	A-phase  B-phase 	A-phase  B-phase 	[1]	Inverted	A-phase  B-phase 	A-phase  B-phase 
Pr0.12	Phase B logic	CW direction	CCW direction																	
[0]	Not inverted	A-phase  B-phase 	A-phase  B-phase 																	
[1]	Inverted	A-phase  B-phase 	A-phase  B-phase 																	

Pr0.13	Label	1 st Torque Limit			Mode	P	V	T
	Range	0~500	Unit	%	Default	300	Index	2013h
	Activation	Immediate						
<p>1st torque limit is set according to ratio percentage of motor rated current. Do not exceed max driver output current. Actual torque limit is the smaller value of Pr0.13 and object dictionary 6072</p>								

Pr0.14	Label	Excessive Position Deviation Settings			Mode	P		
	Range	0~500	Unit	0.1rev	Default	30	Index	2014h
	Activation	Immediate						
<p>Please set threshold value for position deviation accordingly. Default factory setting = 30, Er180 will be triggered if positive deviation is in excess of 3 revolutions.</p>								

Pr0.15	Label	Absolute Encoder settings			Mode	P	V	T
	Range	0~32767	Unit	-	Default	0	Index	2015h
	Activation	Immediate						
<p>0: Incremental mode: Used as an incremental encoder. Doesn't retain position data on power off. Unlimited travel distance.</p> <p>1: Multiturn linear mode: Used as a multiturn absolute encoder. Retrain position data on power off. For applications with fixed travel distance and no multiturn data overflow.</p> <p>2: Multiturn rotary mode: Used as a multiturn absolute encoder. Retrain position data on power off. Actual data feedback in between 0-(Pr6.63). Unlimited travel distance.</p> <p>3: Single turn absolute mode: Used when travel distance is within 1 revolution of the encoder. Data overflow will trigger alarm.</p> <p>5: Clear multiturn alarm and activate multiturn absolute function. Will switch to multiturn mode once alarm cleared, if remains at 5 after 3s, please solve according to Er153.</p>								

9: Clear multiturn position, reset multiturn alarm and activate multiturn absolute function. Will switch to multiturn mode once alarm cleared, if remains at 9 after 3s, please solve according to Er153. Please disable axis before setting to 9 and home the axis before using.

Pr0.16	Label	Regenerative resistance			Mode	P	V	T
	Range	40~500	Unit	Ohm	Default	100	Index	2016h
	Activation	Immediate						
To set resistance value of regenerative resistor								

Pr0.17	Label	Regenerative resistor power rating			Mode	P	V	T
	Range	20~5000	Unit	W	Default	50	Index	2017h
	Activation	Immediate						
To set power rating of regenerative resistor. Pr0.16 and Pr0.17 determines the threshold value of Er 120. Please set accordingly or it might trigger false alarm or damage to servo driver. <i>Note: If external regenerative resistor is used, please set according to its labeled power rating.</i>								

Pr0.19	Label	Friction compensation setting			Mode	P	V	T
	Range	0~1000	Unit	-	Default	0	Index	2019h
	Activation	Immediate						
Friction compensation setting = 0, default = 1; Friction compensation setting = x, indicating x+1/10000 of friction compensation runway;								

Pr0.23	Label	EtherCAT slave ID			Mode	P	V	T
	Range	0~32767	Unit	—	Default	2	Index	2023h
	Activation	After restart						
Set ID number of the slave station under EtherCAT mode								

Pr0.24	Label	Source of slave ID			Mode	P	V	T
	Range	0~1	Unit	—	Default	1	Index	2024h
	Activation	After restart						
0: Master device automatically assigns a slave address. 1: The slave ID = Pr0.23								

Pr0.25	Label	Synchronous compensation time 1			Mode	P		
	Range	1~100	Unit	0.1us	Default	10	Index	2025h
	Activation	After restart						
Synchronous dithering compensation range. Used for master device with poor synchronization.								

Pr0.26	Label	Synchronous compensation time 2			Mode	P		
	Range	1~2000	Unit	0.1us	Default	50	Index	2026h
	Activation	After restart						
Synchronous dithering compensation range. Used for master device with poor synchronization.								

Pr0.27	Label	Synchronization mode command delay cycle counts			Mode	P		
	Range	1~50	Unit	-	Default	0	Index	2027h
	Activation	After restart						
Driver delays N position loop cycle counts to receive position command from master device. To solve motor jitter caused by master device with poor synchronization.								

Pr0.28	Label	CSP mode safe self-running position setting			Mode	P		
	Range	0~1000 0	Unit	-	Default	10	Index	2028h
	Activation	Immediate						
Synchronous dithering compensation range. Used for master device with poor synchronization.								

【Class 1】 Gain Adjustments

Pr1.00	Label	1 st position loop gain			Mode	P		
	Range	0~3000 0	Unit	0.1/s	Default	320	Index	2100h
	Activation	Immediate						
<p>Higher position loop gain value improves the responsiveness of the servo driver and lessens the positioning time.</p> <p>Position loop gain value shouldn't exceed responsiveness of the mechanical system and take in consideration velocity loop gain, if not it might cause vibration, mechanical noise and overtravel.</p> <p>As velocity loop gain is based on position loop gain, please set both values accordingly.</p> <p>Recommended range: $1.2 \leq Pr1.00/Pr1.01 \leq 1.8$</p>								

Pr1.01	Label	1 st velocity loop gain			Mode	P	V	T
	Range	1~32767	Unit	0.1Hz	Default	180	Index	2101h
	Activation	Immediate						
<p>To determine the responsiveness of the velocity loop. If inertia ratio of Pr0.04 is uniform with actual inertia ratio, velocity loop responsiveness = Pr1.01.</p> <p>To increase position loop gain and improve responsiveness of the whole system, velocity loop gain must be set at higher value. Please notice that if the velocity loop gain is too high, it might cause vibration.</p>								

Pr1.02	Label	1 st Integral Time Constant of Velocity Loop			Mode	P	V	T
	Range	1~10000	Unit	0.1ms	Default	310	Index	2102h
	Activation	Immediate						

If auto gain adjusting function is not enabled, Pr1.02 is activated.
 The lower the set value, the closer the lag error at stop to 0 but might cause vibration. If the value set is overly large, overshoot, delay of positioning time duration and lowered responsiveness might occur.
 Set 10000 to deactivate Pr1.02.
 Recommended range: $50000 \leq PA1.01 \times PA1.02 \leq 150000$

For example: Velocity loop gain Pr1.01=500(0.1Hz), which is 50Hz. Integral time constant of velocity loop should be $100(0.1ms) \leq Pr1.02 \leq 300(0.1ms)$

Pr1.03	Label	1 st velocity detection filter			Mode	P	V	T
	Range	0~10000	Unit	—	Default	15	Index	2103h
	Activation	Immediate						

This filter is a low pass filter. It blocks high frequencies which cause system instability from velocity feedback data. The higher the set value, lower frequencies will be blocked and velocity responsiveness will also be lowered. Pr1.03 needs to match velocity loop gain. Please refer to the following table.

Set Value	Velocity Detection Filter Cut-off Frequency(Hz)	Set Value	Velocity Detection Filter Cut-off Frequency(Hz)
0	2500	16	750
1	2250	17	700
2	2100	18	650
3	2000	19	600
4	1800	20	550
5	1600	21	500
6	1500	22	450
7	1400	23	400
8	1300	24	350
9	1200	25	300
10	1100	26	250
11	1000	27	200
12	950	28	175
13	900	29	150
14	850	30	125
15	800	31	100

Pr1.04	Label	1 st Torque Filter Time Constant			Mode	P	V	T
	Range	0~2500	Unit	0.01ms	Default	126	Index	2104h
	Activation	Immediate						
<p>To set torque command low-pass filter, add a filter delay time constant to torque command and filter out the high frequencies in the command.</p> <p>Often used to reduce or eliminate some noise or vibration during motor operation, but it will reduce the responsiveness of current loop, resulting in undermining velocity loop and position loop control. Pr1.04 needs to match velocity loop gain.</p> <p>Recommended range: $1,000,000/(2\pi \times \text{Pr1.04}) \geq \text{Pr1.01} \times 4$</p> <p>For example: Velocity loop gain Pr1.01=180(0.1Hz) which is 18Hz. Time constant of torque filter should be $\text{Pr1.01} \leq 221(0.01\text{ms})$</p> <p>If mechanical vibration is due to servo driver, adjusting Pr1.04 might eliminate the vibration. The smaller the value, the better the responsiveness but also subjected to machine conditions. If the value is too large, it might lower the responsiveness of current loop.</p> <p>With higher Pr1.01 value settings and no resonance, reduce Pr1.04 value; With lower Pr1.01 value settings, increase Pr1.04 value to lower motor noise.</p>								

Pr1.05	Label	2 nd Position Loop Gain			Mode	P	V	T
	Range	0~30000	Unit	0.1/s	Default	380	Index	2105h
	Activation	Immediate						

Pr1.06	Label	2 nd velocity loop gain			Mode	P	V	T
	Range	1~32767	Unit	0.1Hz	Default	180	Index	2106h
	Activation	Immediate						

Pr1.07	Label	2 nd Integral Time Constant of Velocity Loop			Mode	P	V	T
	Range	1~10000	Unit	0.1ms	Default	10000	Index	2107h
	Activation	Immediate						

Pr1.08	Label	2 nd velocity detection filter			Mode	P	V	T
	Range	0~31	Unit	—	Default	15	Index	2108h
	Activation	Immediate						

Pr1.09	Label	2 nd Torque Filter Time Constant			Mode	P	V	T
	Range	0~2500	Unit	0.01ms	Default	126	Index	2109h
	Activation	Immediate						
Position loop, velocity loop, velocity detection filter, torque command filter each have 2 pairs of gain or time constant (1st and 2nd).								

Pr1.10	Label	Velocity feed forward gain			Mode	P		
	Range	0~1000	Unit	0.10%	Default	300	Index	2110h
	Activation	Immediate						
Used for decreasing following error caused by low responsiveness of velocity loop. Might cause overshoot or increase in noise if set value is too high.								

Pr1.11	Label	Velocity feed forward filter time constant			Mode	P		
	Range	0~6400	Unit	0.01ms	Default	50	Index	2111h
	Activation	Immediate						
<p>Set velocity feed forward low pass filter to eliminate high or abnormal frequencies in velocity feed forward command. Often used when position command with low resolution or high electronic gear ratio to smoothen velocity feed forward.</p> <p>Position deviation under constant velocity can be lowered with higher velocity feed forward gain. Please to refer to the equation below.</p> $\text{Position deviation[Uint]} = \frac{\text{Set velocity} \left[\frac{\text{Unit}}{\text{s}} \right]}{\text{Position loop gain[Hz]} } \times \frac{100 - \text{Velocity feed forward gain}[\%]}{100}$								

Pr1.12	Label	Torque feed forward gain			Mode	P	V	
	Range	0~1000	Unit	0.1%	Default	0	Index	2112h
	Activation	Immediate						
Before using torque feed forward, please set correct inertia ratio. By increasing torque feed forward gain, position deviation on constant acceleration/deceleration can be reduced to close to 0. Under ideal condition and trapezoidal speed profile, position deviation of the whole motion can be reduced to close to 0. In reality, perturbation torque will always exist, hence position deviation can never be 0.								

Pr1.13	Label	Torque feed forward filter time constant			Mode	P	V	
	Range	0~6400	Unit	0.01ms	Default	0	Index	2113h
	Activation	Immediate						
<p>Low pass filter to eliminate abnormal or high frequencies in torque feed forward command. Usually used when encoder has lower resolution or precision. Noise reduces if torque feed forward filter time constant is set higher but position deviation will increase at acceleration varied points.</p>								

Pr1.15	Label	Position control gain switching mode			Mode	P		
	Range	0~11	Unit	—	Default	0	Index	2115h
	Activation	Immediate						

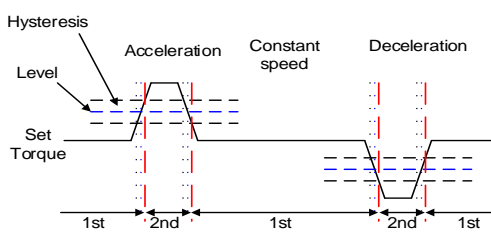
Set Value	Condition	Gain switching condition
0	1 st gain fixed	Fixed on using 1 st gain(Pr1.00-Pr1.04)
1	2 nd gain fixed	Fixed on using 2 nd gain (Pr1.05-Pr1.09)
2	Reserved	
3	High set torque	<p>Switch to 2nd gain when set torque command absolute value larger than (level + hysteresis)[%] Switch to 1st gain when set torque command absolute value smaller than (level + hysteresis)[%]</p> 
4	Reserved	Reserved
5	High set velocity	Valid for position and velocity control. Switch to 2 nd gain when set velocity command absolute

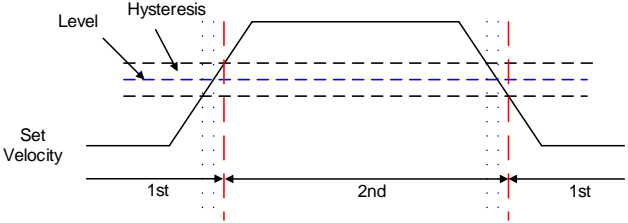
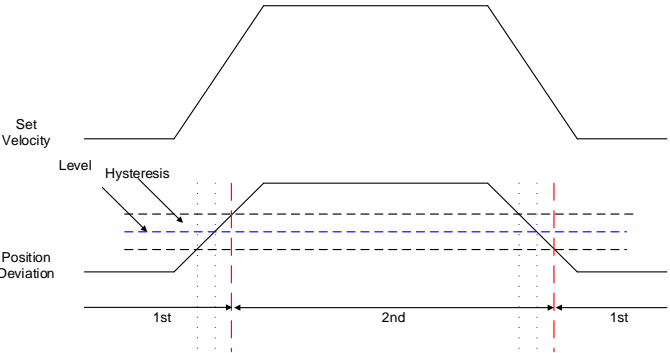
		 <p>value larger than $(\text{level} + \text{hysteresis})[\text{r/min}]$ Switch to 1st gain when set velocity command absolute value smaller than $(\text{level} - \text{hysteresis})[\text{r/min}]$</p>
<p>6</p>	<p>Large position deviation</p>	<p>Valid for position control. Switch to 2nd gain when position deviation absolute value larger than $(\text{level} + \text{hysteresis})[\text{pulse}]$ Switch to 1st gain when position deviation absolute value smaller than $(\text{level} - \text{hysteresis})[\text{pulse}]$</p> 

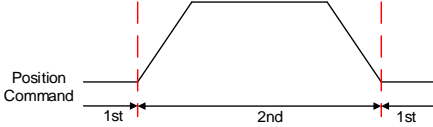
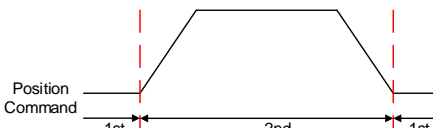
<p>7</p>	<p>Pending position command</p>	<p>Valid for position control. Switch to 2nd gain if position command $\neq 0$ Switch to 1st gain if position command remains = 0 throughout the duration of delay time.</p> 
<p>8</p>	<p>Not yet in position</p>	<p>Valid for position control. Switch to 2nd gain if position command is not completed. Switch to 1st gain if position command remains uncompleted throughout the duration of delay time.</p> 
<p>9</p>	<p>High actual velocity</p>	<p>Valid for position control. Switch to 2nd gain when actual velocity absolute value larger than (level + hysteresis)[r/min] Switch to 1st gain when actual velocity absolute value remains smaller throughout the duration of delay time than (level-hysteresis)[r/min]</p>

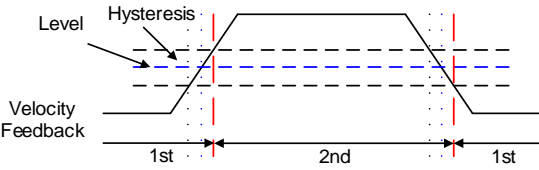
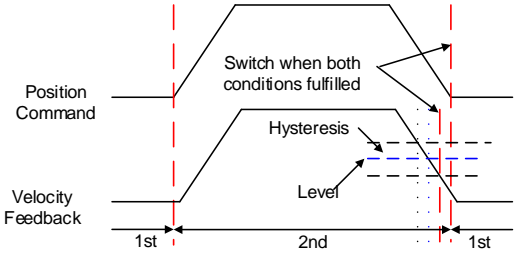
		
10	Pending position command + actual velocity	<p>Valid for position control. Switch to 2nd gain if position command $\neq 0$ Switch to 1st gain if positional command = 0 throughout the duration of delay time and absolute value of actual velocity remains smaller than (level - hysteresis) (r/min)</p> 

For position control mode, set Pr1.15=3,5,6,9,10;

**** Above 'level' and 'hysteresis' are in correspondence to Pr1.17 Position control gain switching level and Pr1.18 Hysteresis at position control switching.**

Pr1.17	Label	Position control gain switching level			Mode	P										
	Range	0~2000 0	Unit	Mode dependent	Default	50	Index	2117h								
	Activation	Immediate														
<p>Set threshold value for gain switching to occur. Unit is mode dependent.</p> <table border="1"> <thead> <tr> <th>Switching condition</th> <th>Unit</th> </tr> </thead> <tbody> <tr> <td>Position</td> <td>Encoder pulse count</td> </tr> <tr> <td>Velocity</td> <td>RPM</td> </tr> <tr> <td>Torque</td> <td>%</td> </tr> </tbody> </table> <p><i>Please set level \geq hysteresis</i></p>									Switching condition	Unit	Position	Encoder pulse count	Velocity	RPM	Torque	%
Switching condition	Unit															
Position	Encoder pulse count															
Velocity	RPM															
Torque	%															

Pr1.18	Label	Hysteresis at position control switching			Mode	P		
	Range	0~2000 0	Unit	Mode dependent	Default	33	Index	2118h
	Activation	Immediate						
<p>To eliminate the instability of gain switching. Used in combination with Pr1.17 using the same unit. If level < hysteresis, drive will set internally hysteresis = level.</p>								

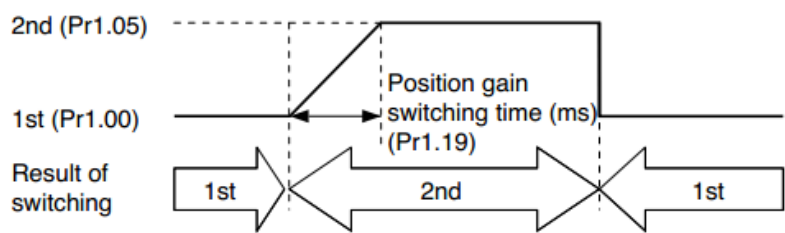
Pr1.19	Label	Position gain switching time			Mode	P		
	Range	0~1000 0	Unit	0.1ms	Default	33	Index	2119h
	Activation	Immediate						
<p>During position control, to ease torque changes and vibration due to rapid changes in position loop gain, set suitable Pr1.19 value For example: 1st (pr1.00) <-> 2nd (Pr1.05)</p> 								

Pr1.35	Label	Position command pulse filter time			Mode	P		
	Range	0~200	Unit	20ns	Default	20	Index	2135h
	Activation	Immediate						
<p>To eliminate interfering narrow band pulse train from position command pulse. If value set is too high, it might interfere high frequency position command pulse receiving and causes large delays.</p> <p>Pr1.35 calculation formula:</p> $\text{Filter frequency} = \frac{1}{2 \times \text{Pr1.35} \times 0.05\mu\text{s}} \times 1\,000\,000\text{Hz}$								

【Class 2】 Vibration Suppression

Pr2.00	Label	Adaptive filtering mode settings			Mode	P	V																
	Range	0~4	Unit	-	Default	0	Index	2200h															
	Activation	Immediate																					
<table border="1"> <thead> <tr> <th>Set value</th> <th colspan="2">Explanation</th> </tr> </thead> <tbody> <tr> <td>0</td> <td>Adaptive filter: invalid</td> <td>Parameters related to 3rd and 4th notch filter remain unchanged</td> </tr> <tr> <td>1</td> <td>Adaptive filter: 1 filter valid for once.</td> <td>1 adaptive filter becomes valid. 3rd notch filter related parameters updated accordingly. Pr2.00 switches automatically to 0 once updated.</td> </tr> <tr> <td>2</td> <td>Adaptive filter: 1 filter remains valid</td> <td>1 adaptive filter becomes valid. 3rd notch filter related parameters will keep updating accordingly.</td> </tr> <tr> <td>3-4</td> <td>Reserved</td> <td>-</td> </tr> </tbody> </table>									Set value	Explanation		0	Adaptive filter: invalid	Parameters related to 3 rd and 4 th notch filter remain unchanged	1	Adaptive filter: 1 filter valid for once.	1 adaptive filter becomes valid. 3 rd notch filter related parameters updated accordingly. Pr2.00 switches automatically to 0 once updated.	2	Adaptive filter: 1 filter remains valid	1 adaptive filter becomes valid. 3 rd notch filter related parameters will keep updating accordingly.	3-4	Reserved	-
Set value	Explanation																						
0	Adaptive filter: invalid	Parameters related to 3 rd and 4 th notch filter remain unchanged																					
1	Adaptive filter: 1 filter valid for once.	1 adaptive filter becomes valid. 3 rd notch filter related parameters updated accordingly. Pr2.00 switches automatically to 0 once updated.																					
2	Adaptive filter: 1 filter remains valid	1 adaptive filter becomes valid. 3 rd notch filter related parameters will keep updating accordingly.																					
3-4	Reserved	-																					

Pr2.01	Label	1 st notch frequency			Mode	P	V	T
	Range	50~4000	Unit	Hz	Default	4000	Index	2201h
	Activation	Immediate						
<p>Set center frequency of 1st torque command notch filter. Set Pr2.01 to 4000 to deactivate notch filter</p>								

Pr2.02	Label	1 st notch bandwidth selection			Mode	P	V	T
	Range	0~20	Unit	-	Default	4	Index	2202h
	Activation	Immediate						
<p>Set notch bandwidth for 1st resonant notch filter. Under normal circumstances, please use factory default settings. If resonance is under control, in combination with Pr2.01 and Pr2.03, Pr2.02 can be reduced to improve current loop responsiveness which allows higher mechanical stiffness settings.</p>								

Pr2.03	Label	1 st notch depth selection			Mode	P	V	T
	Range	0~99	Unit	-	Default	0	Index	2203h
	Activation	Immediate						
<p>Set notch depth for 1st resonant notch filter. Under normal circumstances, please use factory default settings. If resonance is under control, in combination with Pr2.01 and Pr2.02, Pr2.03 can be reduced to improve current loop responsiveness which allows higher mechanical stiffness settings.</p>								

Pr2.04	Label	2 nd notch frequency			Mode	P	V	T
	Range	50~4000	Unit	Hz	Default	4000	Index	2204h
	Activation	Immediate						
<p>Set center frequency of 2nd torque command notch filter. Set Pr2.04 to 4000 to deactivate notch filter</p>								

Pr2.05	Label	2 nd notch bandwidth selection			Mode	P	V	T
	Range	0~20	Unit	-	Default	4	Index	2205h
	Activation	Immediate						
<p>Set notch bandwidth for 2nd resonant notch filter. Under normal circumstances, please use factory default settings. If resonance is under control, in combination with Pr2.04 and Pr2.06, Pr2.05 can be reduced to improve current loop responsiveness which allows higher mechanical stiffness settings.</p>								

Pr2.06	Label	2 nd notch depth selection			Mode	P	V	T
	Range	0~99	Unit	-	Default	0	Index	2206h
	Activation	Immediate						
<p>Set notch depth for 1st resonant notch filter. When Pr2.06 value is higher, notch depth becomes shallow, phase lag reduces. Under normal circumstances, please use factory default settings. If resonance is under control, in combination with Pr2.04 and Pr2.05, Pr2.06 can be reduced to improve current loop responsiveness which allows higher mechanical stiffness settings.</p>								

Pr2.07	Label	3 rd notch frequency			Mode	P	V	T
	Range	50~400 0	Unit	Hz	Default	4000	Index	2207h
	Activation	Immediate						
<p>Set center frequency of 3rd torque command notch filter. Set Pr2.07 to 4000 to deactivate notch filter</p>								

Pr2.08	Label	3 rd notch bandwidth selection			Mode	P	V	T
	Range	0~20	Unit	-	Default	4	Index	2287h
	Activation	Immediate						
<p>Set notch bandwidth for 3rd resonant notch filter. Under normal circumstances, please use factory default settings.</p>								

Pr2.09	Label	3 rd notch depth selection			Mode	P	V	T
	Range	0~99	Unit	-	Default	0	Index	2206h
	Activation	Immediate						
<p>Set notch depth for 1st resonant notch filter. When Pr2.09 value is higher, notch depth becomes shallow, phase lag reduces.</p>								

Pr2.14	Label	1 st damping frequency			Mode	P	V	T
	Range	0~2000	Unit	0.1Hz	Default	0	Index	2214h
	Activation	Immediate						
<p>0: Deactivate</p> <p>To suppress wobble at load end. Often used when wobble of flexible structure due to high deceleration upon stopping. Especially effective for wobble with frequencies under 100Hz. Set Pr2.15 to wobble frequency (wobble frequency can be determined using tracing function of Motion Studio)</p>								

Pr2.16	Label	2 nd damping frequency		Mode	P			
	Range	0~2000	Unit	0.1Hz	Default	0	Index	2216h
	Activation	Immediate						

0: Deactivate

To suppress wobble at load end. Often used when wobble of flexible structure due to high deceleration upon stopping. Especially effective for wobble with frequencies under 100Hz. Set Pr2.15 to wobble frequency (wobble frequency can be determined using tracing function of Motion Studio)

Pr2.22	Label	Position command smoothing filter		Mode	P			
	Range	0~32767	Unit	0.1ms	Default	0	Index	2222h
	Activation	Stop axis						

To set time constant of 1 time delay filter of position command.
 To set time constant of 1 time delay filter, according to target velocity V_c square wave command as show below.

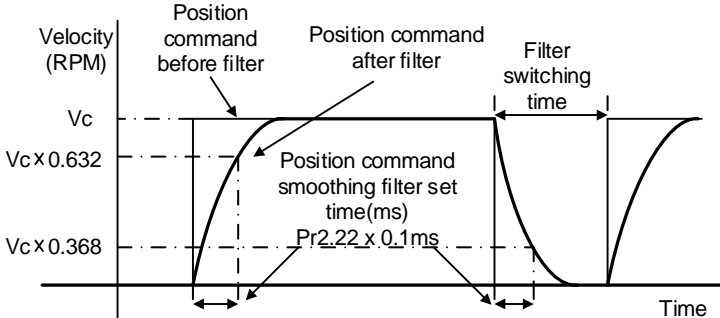

Usually applied when there is rather sharp acceleration which might cause motor overshoot or undershoot. To smoothen command signal, reduces impact to machines and eliminate vibration. If Pr2.22 is set too high, overall time will be lengthened.

Pr2.23	Label	Position command FIR filter		Mode	P			
	Range	0~10000	Unit	0.1ms	Default	0	Index	2223h
	Activation	Disable axis						

As shown below, when target velocity V_c square wave command reaches V_c , it becomes trapezoidal wave after filtering.

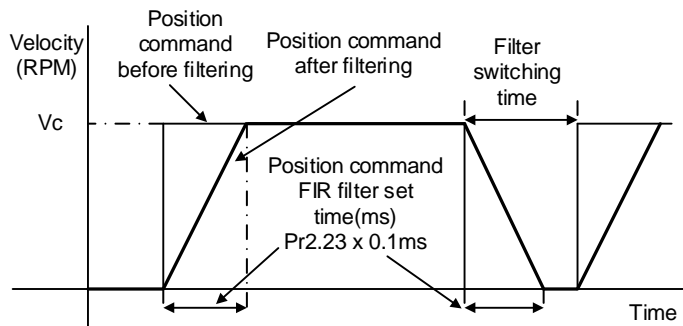

As shown below, when target velocity V_c trapezoidal command reaches V_c , it becomes S wave after filtering.

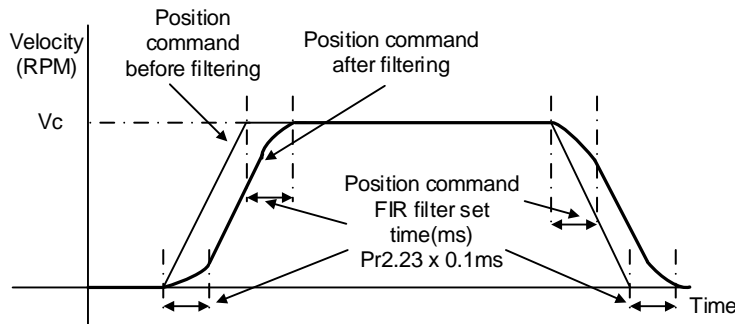

Usually applied when there is rather sharp acceleration which might cause motor overshoot or undershoot. To smoothen command signal, reduces impact to machines and eliminate vibration. If Pr2.23 is set too high, overall time will be lengthened.

***Please wait for command to stop and after filter idle time to modify Pr2.23.*

Filter switching time = (Pr2.23 set value x 0.1ms + 0.25ms)

Pr2.31	Label	5 th resonant frequency		Mode	P	V	T	
	Range	50~400 0	Unit	Hz	Default	4000	Index	2231h
	Activation	Immediate						

To set zero-valued eigenfrequency of 5th resonant notch filter. Pr2.31 corresponds to machine specific resonant frequency.

Notch filter deactivated if Pr2.31 is set to any value.

Pr2.32	Label	5 th resonant Q value			Mode	P	V	T
	Range	0~10000	Unit	Hz	Default	0	Index	2232h
	Activation	Immediate						
To set notch Q value of 5 th resonant notch filter								

Pr2.33	Label	5 th anti-resonant frequency			Mode	P	V	T
	Range	50~40000	Unit	Hz	Default	4000	Index	2233h
	Activation	Immediate						
To set zero-valued eigenfrequency of 5 th resonant notch filter. Pr2.31 corresponds to machine-specific anti-resonant frequency.								

Pr2.34	Label	5 th anti-resonant Q value			Mode	P	V	T
	Range	0~9900	Unit	Hz	Default	0	Index	2234h
	Activation	Immediate						
To set resonant Q value of 5 th resonant notch filter								

Pr2.35	Label	6 th resonant frequency			Mode	P	V	T
	Range	50~4000	Unit	Hz	Default	4000	Index	2235h
	Activation	Immediate						
To set zero-valued eigenfrequency of 6 th resonant notch filter. Pr2.35 corresponds to machine-specific resonant frequency. Notch filter deactivated if Pr2.31 is set to any value.								

Pr2.36	Label	6 th resonant Q value			Mode	P	V	T
	Range	0~10000	Unit	Hz	Default	0	Index	2236h
	Activation	Immediate						
To set notch Q value of 6 th resonant notch filter								

Pr2.37	Label	6 th anti-resonant frequency			Mode	P	V	T
	Range	50~40000	Unit	Hz	Default	4000	Index	2237h
	Activation	Immediate						
To set zero-valued eigenfrequency of 6 th resonant notch filter. Pr2.37 corresponds to machine-specific anti-resonant frequency.								

Pr2.38	Label	6 th anti-resonant Q value			Mode	P	V	T
	Range	0~9900	Unit	Hz	Default	0	Index	2238h
	Activation	Immediate						
To set resonant Q value of 6 th resonant notch filter								

【Class 3】 Velocity/ Torque Control

Pr3.00	Label	Internal/External settings of velocity settings			Mode		V	
	Range	0~3	Unit	-	Default	1	Index	2300h
	Activation	Immediate						

Internal velocity settings can be achieved by connecting to driver's input interface.

Set value	Velocity settings
0	Analog velocity command (SPR)
[1]	Internal velocity command: 1 st to 4 th speed (Pr3.04 to Pr3.07)
2	Internal velocity command 1 st to 3 rd speed (Pr3.04 to Pr3.06), Analog velocity command (SPR)
3	Internal velocity command 1 st to 8 th speed (Pr3.00 to Pr3.11)

Table below shows relationship between Pr3.00 and internal velocity command

Set value	Selection 1 of internal velocity command (INTSPD1)	Selection 2 of internal velocity command (INTSPD2)	Selection 3 of internal velocity command (INTSPD3)	Selection of velocity command
1	OFF	OFF	No effect	1 st speed
	ON	OFF		2 nd speed
	OFF	ON		3 rd speed
	ON	ON		4 th speed
2	OFF	OFF	No effect	1 st speed
	ON	OFF		2 nd speed
	OFF	ON		3 rd speed
	ON	ON		Analog speed command
3	ON	ON	OFF	1 st to 4 th speed
	OFF	OFF	ON	5 th speed
	ON	OFF	ON	6 th speed
	OFF	ON	ON	7 th speed
	ON	ON	ON	8 th speed

Please refer to diagrams below change internal speed command one-by-one. Changing more

than 1 at the same time might incur unexpected circumstances.

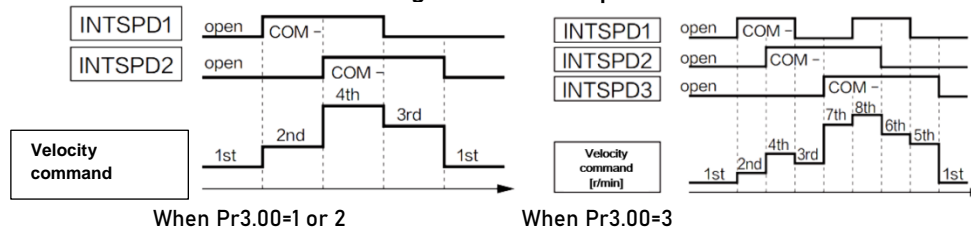

Pr3.01	Label	Velocity command rotational direction selection			Mode		V	T
	Range	0~1	Unit	-	Default	0	Index	2301h
	Activation	Immediate						

Set value	Velocity command sign(1 st to 8 th speed)	Velocity command direction(VC-SIGN)	Position command direction
0	+	No effect	Positive direction
	-	No effect	Negative direction
1	Sign has no effect.	OFF	Positive direction
	Sign has no effect	ON	Negative direction

Pr3.02	Label	Velocity command input gain			Mode		V	
	Range	10~200 0	Unit	(r/min)/V	Default	500	Index	2302h
	Activation	Immediate						

Set conversion gain from voltage applied to the analog velocity command (SPR) to motor velocity command.

- Use Pr3.02 to set the slope for relation between command input voltage and rotational velocity.
- Default is set to Pr3.02=500 [r/min] hence input of 6V is 3000 r/min.

1. Do not apply more than ±10 V to analog velocity command (SPR).
2. While in velocity control mode in combination with driver external position loop, position gain of the driver will have changes. Vibration might occur if Pr3.02 is set too large.

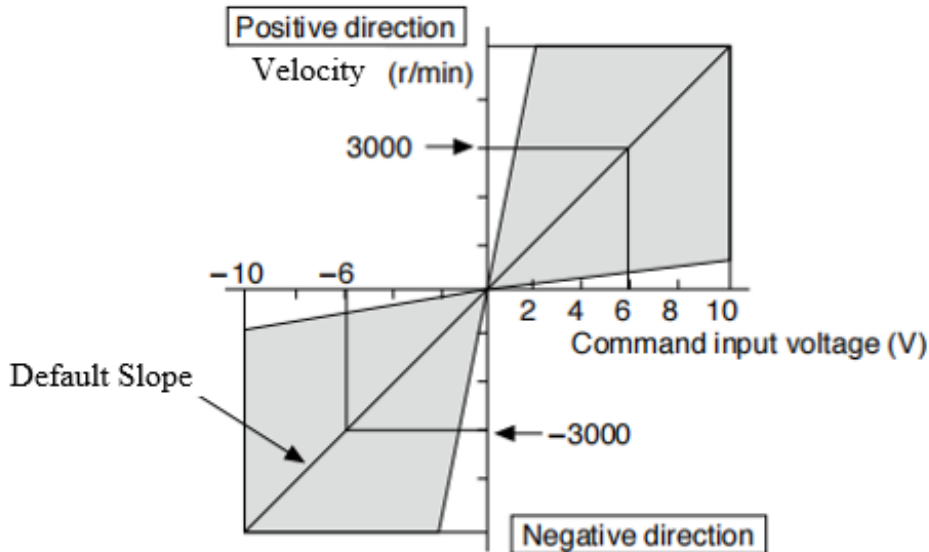

Pr3.03	Label	Velocity command input inversion			Mode		V	
	Range	0~1	Unit	-	Default	0	Index	2303h
	Activation	Immediate						

Specify the polarity of the voltage applied to the analog velocity command (SPR).

Set value	Motor rotational direction	
0	Non-reversal	" +Voltage" → "Positive direction" " -Voltage" → "Negative direction"
1	Reversal	" +Voltage" → "Negative direction" " -Voltage" → "Positive direction"

While servo driver is set on simulated velocity control and in combination with external positioning device, motor might undergo abnormal behavior when velocity command signal polarity from external positioning device doesn't match the polarity set in Pr3.03

Pr3.04	Label	1 st speed of velocity setting			Mode		V	
	Range	-10000~10000	Unit	r/min	Default	0	Index	2304h
	Activation	Immediate						
Pr3.05	Label	2 nd speed of velocity setting			Mode		V	
	Range	-10000~10000	Unit	r/min	Default	0	Index	2305h
	Activation	Immediate						
Pr3.06	Label	3 rd speed of velocity setting			Mode		V	
	Range	-10000~10000	Unit	r/min	Default	0	Index	2306h
	Activation	Immediate						
Pr3.07	Label	4 th speed of velocity setting			Mode		V	
	Range	-10000~10000	Unit	r/min	Default	0	Index	2307h
	Activation	Immediate						
Pr3.08	Label	5 th speed of velocity setting			Mode		V	
	Range	-10000~10000	Unit	r/min	Default	0	Index	2308h
	Activation	Immediate						
Pr3.09	Label	6 th speed of velocity setting			Mode		V	
	Range	-10000~10000	Unit	r/min	Default	0	Index	2309h
	Activation	Immediate						
Pr3.10	Label	7 th speed of velocity setting			Mode		V	
	Range	-10000~10000	Unit	r/min	Default	0	Index	2310h
	Activation	Immediate						
Pr3.11	Label	8 th speed of velocity setting			Mode		V	
	Range	-10000~10000	Unit	r/min	Default	0	Index	2311h
	Activation	Immediate						
Set internal velocity commands, 1 st to 8 th speed								
Pr3.12	Label	Acceleration time settings			Mode		V	
	Range	0~10000	Unit	ms/(1000RPM)	Default	0	Index	2312h
	Activation	Immediate						

Pr3.13	Label	Deceleration time settings		Mode	V			
	Range	0~10000	Unit	ms/ (1000RPM)	Default	0	Index	2313h
	Activation	Immediate						

Set max acceleration/deceleration for velocity command.

If target velocity = x [rpm], max acceleration = a [unit: rpm/ms], acceleration time = t [ms]

$$\text{Pr3.12} = 1000/a$$

$$\text{Pr3.13} = 1000/a$$

$$a = x/t$$

For example: If motor is to achieve 1500rpm in 30s, $a=1500/30=50\text{rpm/ms}$

Pr3.12 = $1000/a=20$. Hence when Pr3.12 = 20, motor can achieve 1500rpm in 30s.

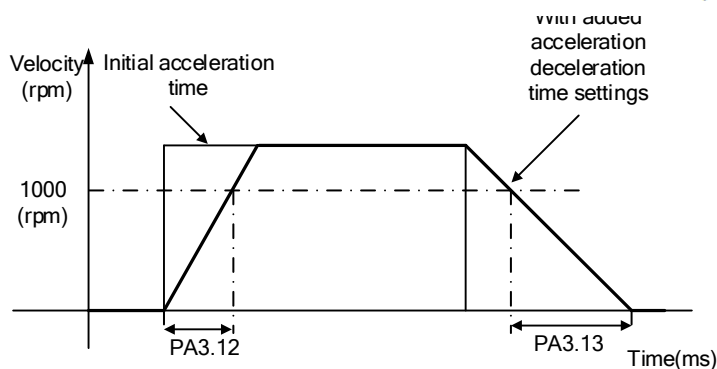
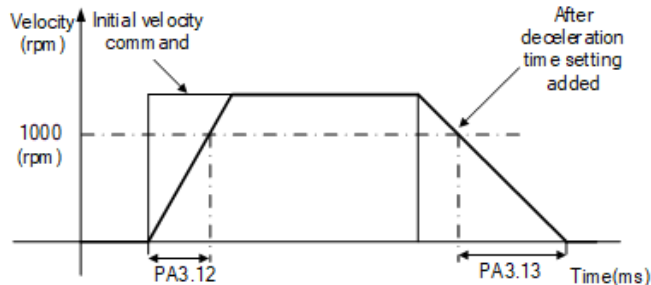

Usually used when there is rapid acceleration or trapezoidal wave velocity command due to many different internal speed segments under velocity control mode which causes instable while motor in motion.

Under velocity control mode, 6083 and 6084 is limited by Pr3.12 and Pr3.13 correspondingly.

Pr3.14	Label	Sigmoid acceleration/deceleration settings			Mode			V	
	Range	0~1000	Unit	ms	Default	0	Index	2314h	
	Activation	Axis disable							

To set sigmoid acceleration and deceleration turning point in accordance to Pr3.12 and Pr3.13.

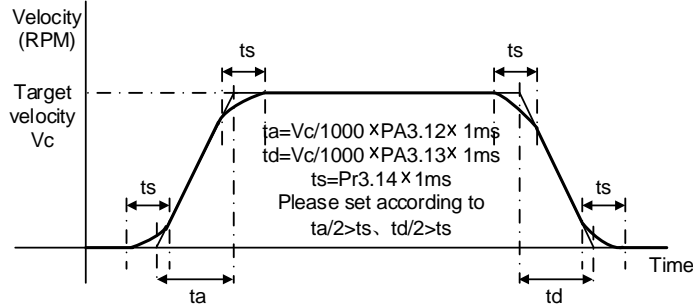

Pr3.15	Label	Zero speed clamp function selection			Mode			V	
	Range	0~3	Unit	-	Default	0	Index	2315h	
	Activation	Immediate							

Set value	Zero speed clamp function
0	Invalid: zero speed clamp deactivated
1	Velocity command is forced to 0 when the zero speed clamp (ZEROSPD) input signal is valid.
2	Velocity command is forced to 0 when actual velocity is lower than Pr3.16.
3	Includes conditions from 1 and 2

Pr3.16	Label	Zero speed clamp level			Mode			V	
	Range	10~2000	Unit	RPM	Default	30	Index	2316h	
	Activation	Immediate							

Velocity command is forced to 0 when actual velocity is lower than Pr3.16 and after static time set in Pr3.23

Pr3.17	Label	Internal/External settings of torque			Mode			T															
	Range	0~3	Unit	-	Default	0	Index	2317h															
	Activation	Immediate																					
<table border="1"> <thead> <tr> <th>Set value</th> <th>Torque command input</th> <th>Velocity limit input</th> </tr> </thead> <tbody> <tr> <td>0</td> <td>Analog input 3 (AI3)</td> <td>Parameter value (Pr3.21)</td> </tr> <tr> <td>1</td> <td>Analog input 3 (AI3)</td> <td>Analog input 1 (AI1)</td> </tr> <tr> <td>2</td> <td>Parameter value (Pr3.22)</td> <td>Parameter value (Pr3.21)</td> </tr> <tr> <td>3</td> <td>Analog 1 is set by 485</td> <td>Analog 3 is set by 485</td> </tr> </tbody> </table>									Set value	Torque command input	Velocity limit input	0	Analog input 3 (AI3)	Parameter value (Pr3.21)	1	Analog input 3 (AI3)	Analog input 1 (AI1)	2	Parameter value (Pr3.22)	Parameter value (Pr3.21)	3	Analog 1 is set by 485	Analog 3 is set by 485
Set value	Torque command input	Velocity limit input																					
0	Analog input 3 (AI3)	Parameter value (Pr3.21)																					
1	Analog input 3 (AI3)	Analog input 1 (AI1)																					
2	Parameter value (Pr3.22)	Parameter value (Pr3.21)																					
3	Analog 1 is set by 485	Analog 3 is set by 485																					

Pr3.18	Label	Torque command direction selection			Mode			T						
	Range	0~1	Unit	-	Default	0	Index	2318h						
	Activation	Immediate												
<table border="1"> <thead> <tr> <th>Set value</th> <th>Direction</th> </tr> </thead> <tbody> <tr> <td>0</td> <td>Direction as indicator by +/- of torque command input. +input → positive, -input → negative ON/OFF of TC-SIGN has no effect on direction of motion.</td> </tr> <tr> <td>1</td> <td>Direction as indicator by TC-SIGN. OFF: Positive direction, ON: Negative direction +/- torque command input has no effect on direction of motion.</td> </tr> </tbody> </table>									Set value	Direction	0	Direction as indicator by +/- of torque command input. +input → positive, -input → negative ON/OFF of TC-SIGN has no effect on direction of motion.	1	Direction as indicator by TC-SIGN. OFF: Positive direction, ON: Negative direction +/- torque command input has no effect on direction of motion.
Set value	Direction													
0	Direction as indicator by +/- of torque command input. +input → positive, -input → negative ON/OFF of TC-SIGN has no effect on direction of motion.													
1	Direction as indicator by TC-SIGN. OFF: Positive direction, ON: Negative direction +/- torque command input has no effect on direction of motion.													

Pr3.21	Label	Velocity limit value in torque mode			Mode			T
	Range	0~5000	Unit	r/min	Default	0	Index	2321h
	Activation	Immediate						
<p>Only effective when Pr3.17 = 0 or 2 Velocity limit would not exceed value set in Pr3.21 under torque control mode.</p>								

Pr3.22	Label	Torque limit value in torque mode			Mode	P	V	T
	Range	0~500	Unit	%	Default	0	Index	2322h
	Activation	Immediate						
<p>Only effective when Pr3.17 = 0 or 2</p>								

Pr3.23	Label	Zero speed clamp static time			Mode	P	V	T
	Range	0~32767	Unit	ms	Default	0	Index	2323h
	Activation	Immediate						
<p>To set delay time for zero speed clamp. To prevent creeping at low speed, velocity command forced to 0 when velocity goes under Pr3.16 after time set in Pr3.23</p>								

Pr3.24	Label	Maximum motor rotational velocity			Mode	P	V	T
	Range	0~10000	Unit	r/min	Default	0	Index	2324h
	Activation	Immediate						
<p>Maximum motor rotational as accordance to technical specification if set to 0</p>								

【Class 4】 I/O Interface Setting

Pr4.00	Label	Input selection DI1			Mode	P	V	T
	Range	0x0~0xFF	Unit	—	Default	0x0	Index	2400h
	Activation	Immediate						
Pr4.01	Label	Input selection DI2			Mode	P	V	T
	Range	0x0~0xFF	Unit	—	Default	0x1	Index	2401h
	Activation	Immediate						
Pr4.02	Label	Input selection DI3			Mode	P	V	T
	Range	0x0~0xFF	Unit	—	Default	0x2	Index	2402h
	Activation	Immediate						
Pr4.03	Label	Input selection DI4			Mode	P	V	T
	Range	0x0~0xFF	Unit	—	Default	0x16	Index	2403h
	Activation	Immediate						

Digital input DI allocation using hexadecimal system

Input	Symbol	Set value		0x60FD(bit)
		Normally open	Normally close	
Invalid	—	0h	-	×
Positive limit switch	POT	1h	81h	Bit1
Negative limit switch	NOT	2h	82h	Bit0
Servo on	SRV-ON	3h	83h	×
Clear alarm	A-CLR	4h	-	×
Control mode switching	C-MODE	5h	85h	×
Gain switching	GAIN	6h	86h	×
Clear deviation counter	CL	7h	-	×
Command pulse inhibition	INH	8h	88h	×
Torque limit switching	TL-SEL	9h	89h	×
Command pulse divider/multiplier switching	DIV1	Ch	8ch	×
Speed 1 of internal velocity command	INTSPD1	Eh	8Eh	×
Speed 2 of internal velocity command	INTSPD2	Fh	8Fh	×
Speed 3 of internal velocity command	INTSPD3	10h	90h	×
Zero speed clamp	ZEROSPD	11h	91h	×
Velocity command sign	VC-SIGN	12h	92h	×
Torque command sign	TC-SIGN	13h	93h	×
Forced alarm	E-STOP	14h	94h	×
Home switch	HOME-SWITCH	16h	96h	Bit2

· Please don't set anything other than listed in table above.

- Normally open: Valid when input = ON Normally close: Valid when input = OFF
- Er210 might occur if same function is allocated to different channels at the same time
- Channel that has no value doesn't affect driver motion.
- Front panel is of hexadecimal system.
- Pr4.00 – Pr4.03 corresponds to DI1 – DI4. External sensors can be connected if the parameters are all set to 0. Controller will read 60FD bit4 – 7 to get DI1 – DI4 actual status.

Pr4.10	Label	Output selection D01			Mode	P	V	T
	Range	0x0~0xFF	Unit	–	Default	0x1	Index	2410h
	Activation	Immediate						
Pr4.11	Label	Output selection D02			Mode	P	V	T
	Range	0x0~0xFF	Unit	–	Default	0x3	Index	2411h
	Activation	Immediate						
Pr4.12	Label	Output selection D03			Mode	P	V	T
	Range	0x0~0xFF	Unit	–	Default	0x4	Index	2412h
	Activation	Immediate						

Digital output DO allocation using hexadecimal system.

Output	Symbol	Set value	
		Normally open	Normally close
Master device control	–	00h	-
Alarm	ALM	01h	81h
Servo-Ready	S-RDY	02h	82h
External brake released	BRK-OFF	03h	83h
Positioning completed	INP	04h	84h
At-speed	AT-SPEED	05h	85h
Torque limit signal	TLC	06h	86h
Zero speed clamp detection	ZSP	07h	87h
Velocity coincidence	V-COIN	08h	88h
Servo status	SRV-ST	12h	92h
Positive limit	POT-OUT	15h	95h
Negative limit	NOT-OUT	16h	96h
Position command ON/OFF	P-CMD	0Bh	8Bh
Velocity limit signal	V-LIMIT	0Dh	8Dh
Velocity command ON/OFF	V-CMD	0Fh	8Fh
Homing done	HOME-OK	22h	A2h

Please don't set any other than the outputs listed in the table above.

- Normally open: Active low
- Normally close: Active high
- Front panel is of hexadecimal system.
- Pr4.10 – Pr4.12 corresponds to D01 – D03. If all parameters are set to 0, master device controls the outputs, object dictionary 0x60FE sub-index 01 bit16-18 corresponds to D01-D03.

Pr4.31	Label	Positioning complete range			Mode	P		
	Range	0~10000	Unit	Command unit	Default	20	Index	2431h
	Activation	Immediate						
To set position deviation range of INP1 positioning completed output signal.								

Pr4.32	Label	Positioning complete output setting			Mode	P		
	Range	0~4	Unit	-	Default	1	Index	2432h
	Activation	Immediate						
Output conditions of INP1 positioning completed output signal								
Set value		Positioning completed signal						
0		Signal valid when the position deviation is smaller than Pr4.31						
1		Signal valid when there is no position command and position deviation is smaller than Pr4.31						
2		Signal valid when there is no position command, zero-speed clamp detection (ZSP) signal is ON and the positional deviation is smaller than Pr4.31						
3		Signal valid when there is no position command and position deviation is smaller than Pr4.31. Signal ON when within the time set in Pr4.33 otherwise OFF.						
4		When there is no command, position detection starts after the delay time set in Pr4.33. Signal valid when there is no position command and positional deviation is smaller than Pr4.31.						

Pr4.33	Label	INP positioning delay time			Mode	P		
	Range	0~15000	Unit	1ms	Default	0	Index	2433h
	Activation	Immediate						
To set delay time when Pr 4.32 = 3								
Set value		Positioning completed signal						
0		Indefinite delay time, signal ON until next position command						
1-15000		OFF within the time set; ON after time set. Switch OFF after receiving next position command.						

Pr4.34	Label	Zero speed			Mode	P	V	T
	Range	1~2000	Unit	RPM	Default	50	Index	2434h
	Activation	Immediate						

To set threshold value for zero speed clamp detection.
 Zero speed clamp detection (ZSP) output signal valid when motor speed goes under the value set in Pr4.34

- Disregard the direction of rotation, valid for both directions.
- Hysteresis of 10RPM. Please refer to diagram on the right side.

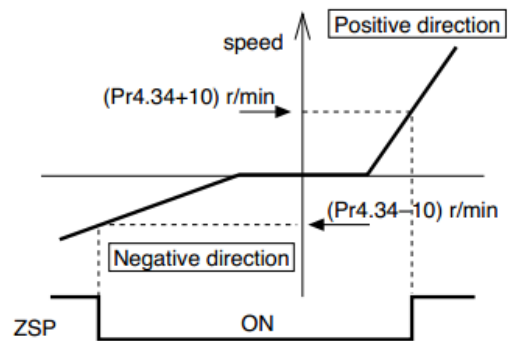

Pr4.35	Label	Velocity coincidence range			Mode		V	
	Range	10~2000	Unit	RPM	Default	50	Index	2435h
	Activation	Immediate						

If the difference between velocity command and motor actual speed is below Pr4.35, Velocity coincidence (V-COIN) output signal valid.

Due to 10RPM hysteresis:
 Velocity coincidence output OFF -> ON timing (Pr4.35 -10) r/min
 Velocity coincidence output ON -> OFF timing (Pr4.35 +10) r/min

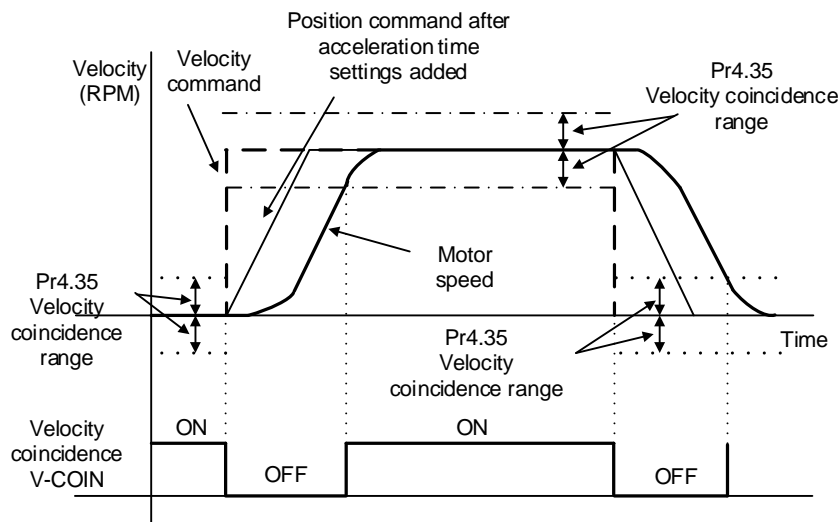

Pr4.36	Label	Arrival velocity (AT-speed)			Mode		V	
	Range	10~2000	Unit	RPM	Default	1000	Index	2436h
	Activation	Immediate						

When motor velocity > Pr4.36, AT-speed output signal is valid.
 Detection using 10RPM hysteresis.

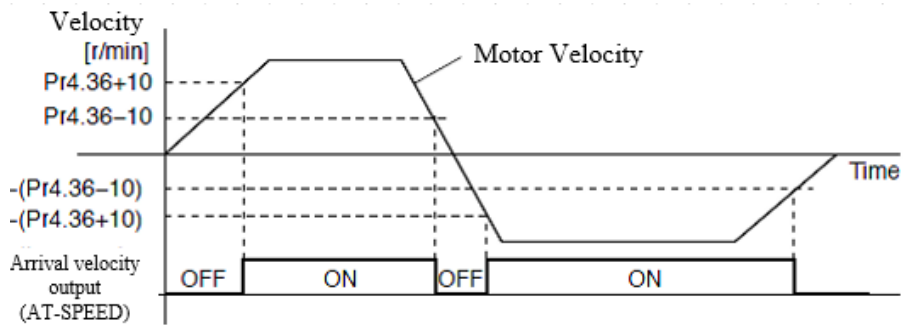

Pr4.37	Label	Motor power-off delay time			Mode	P	V	T
	Range	0~3000	Unit	1ms	Default	100	Index	2437h
	Activation	Immediate						

To set delay time for holding brake to be activated after motor power off to prevent axis from sliding.

Pr4.38	Label	Delay time for holding brake release			Mode	P	V	T
	Range	0~3000	Unit	1ms	Default	0	Index	2438h
	Activation	Immediate						

To set delay time for holding brake to be released after motor power on. Motor will remain at current position and input command is masked to allow holding brake to be fully released before motor is set in motion.

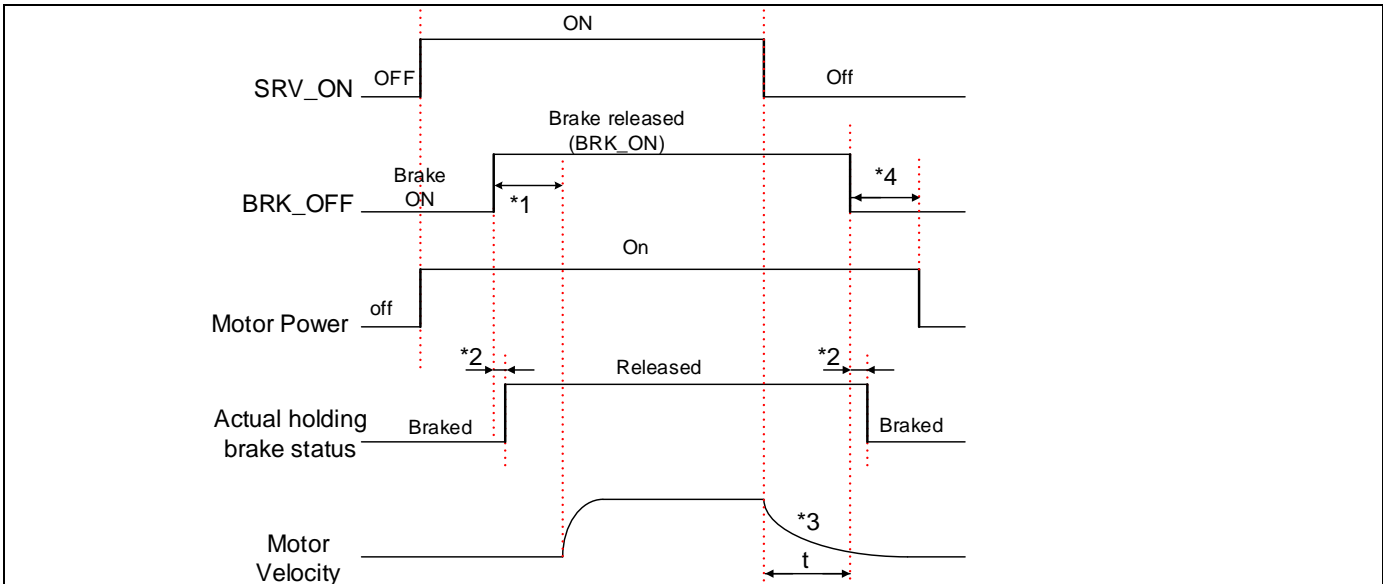

*1: Delay time set in Pr4.38

*2: Delay time from the moment BRK_OFF signal is given until actual holding brake is released or BRK_ON signal is given until actual holding brake is activated. It is dependent on the holding brake of the motor.

*3: Deceleration time is determined by Pr6.14 or if motor speed goes below Pr4.39, whichever comes first. BRK_OFF given after deceleration time.

*4: Pr4.37 set time value.

Delay time from the moment SRV_ON is given until BRK_OFF switch to BRK_ON, is less than 500ms.

Pr4.39	Label	Holding brake activation speed			Mode	P	V	T
	Range	30~3000	Unit	RPM	Default	30	Index	2439h
	Activation	Immediate						

To set the activation speed for which holding brake will be activated.

When SRV-OFF signal is given, motor decelerates, after it reaches below Pr4.39 and Pr6.14 is not yet reached, BRK_OFF is given.

BRK_OFF signal is determined by Pr6.14 or if motor speed goes below Pr4.39, whichever comes first.

Application:

1. After disabling axis, Pr6.14 has been reached but motor speed is still above Pr4.39, BRK_OFF signal given.
2. After disabling axis, Pr6.14 has not been reached but motor speed is below Pr4.39, BRK_OFF signal given.

Pr4.43	Label	Emergency stop function			Mode	P	V	T
	Range	0~1	Unit	-	Default	0	Index	2443h
	Activation	Immediate						
0: Emergency stop is valid, servo driver will be forced to STOP and alarm occurs. 1: Emergency stop is invalid, servo driver will not be forced to STOP.								

【Class 5】 Extension settings

Pr5.00	Label	2 nd pulse count per revolution			Mode	P		
	Range	0~8388608	Unit	P	Default	10000	Index	2500h
	Activation	After restart						
To set command pulse count per revolution for second motor. Switch with Pr0.08 by using I/O interface frequency divider/multiplier switching input signal DIV1 1. When Pr5.00 \neq 0 : Motor revolution = Pulse count input / Pr5.00 2. When Pr5.00 = 0: Actual position pulse count is limited by Pr5.01 and Pr 5.02.								

Pr5.01	Label	2 nd Command frequency divider/multiplier numerator			Mode	P		
	Range	0~1073741824	Unit	-	Default	1	Index	2501h
	Activation	After restart						
To set the numerator of command pulse input frequency divider/multiplier.								

Pr5.02	Label	2 nd Command frequency divider/multiplier denominator			Mode	P		
	Range	0~1073741824	Unit	-	Default	1	Index	2502h
	Activation	After restart						
To set the denominator of command pulse input frequency divider/multiplier.								

Pr5.04	Label	Driver prohibition input settings			Mode	P	V	T								
	Range	0~2	Unit	—	Default	0	Index	2504h								
	Activation	Immediate														
To set driver prohibition input (POT/NOT): If set to 1, no effect on homing mode.																
<table border="1"> <thead> <tr> <th>Set value</th> <th>Explanation</th> </tr> </thead> <tbody> <tr> <td>0</td> <td>POT → Positive direction drive prohibited NOT → Negative direction drive prohibited</td> </tr> <tr> <td>1</td> <td>POT and NOT invalid</td> </tr> <tr> <td>2</td> <td>Any single sided input from POT or NOT might cause Er260</td> </tr> </tbody> </table>									Set value	Explanation	0	POT → Positive direction drive prohibited NOT → Negative direction drive prohibited	1	POT and NOT invalid	2	Any single sided input from POT or NOT might cause Er260
Set value	Explanation															
0	POT → Positive direction drive prohibited NOT → Negative direction drive prohibited															
1	POT and NOT invalid															
2	Any single sided input from POT or NOT might cause Er260															
In homing mode, POT/NOT invalid, please set object dictionary 5012-04 bit0=1																

Pr5.06	Label	Servo-off mode			Mode	P	V	T
	Range	0~5	Unit	—	Default	0	Index	2506h
	Activation	After restart						
To set servo driver disable mode and status.								
Set value		Explanation						
		<i>Mode</i>			<i>Status</i>			
0	Servo braking	Dynamic braking						
1	Free stopping	Dynamic braking						
2	Dynamic braking	Dynamic braking						
3	Servo braking	Free-run						
4	Free stopping	Free-run						
5	Dynamic braking	Free-run						

Pr5.09	Label	Main power-off detection time			Mode	P	V	T
	Range	50~2000	Unit	ms	Default	50	Index	2509h
	Activation	Immediate						
To set duration time for detection of main power-off or low voltage supply.								

Pr5.10	Label	Servo-off due to alarm mode			Mode	P	V	T
	Range	0~2	Unit	-	Default	0	Index	2510h
	Activation	After restart						
To set servo driver disable mode and status if alarm is triggered.								
Alarm type 2:								
Set value		Explanation						
		<i>Mode</i>			<i>Status</i>			
0	Servo braking	Dynamic braking						
1	Free stopping	Dynamic braking						
2	Dynamic braking	Dynamic braking						
3	Servo braking	Free-run						
4	Free stopping	Free-run						
5	Dynamic braking	Free-run						
Alarm type 1:								
Set value		Explanation						
		<i>Mode</i>			<i>Status</i>			
0	Dynamic braking	Dynamic braking						
1								
2	Servo braking	Free-run						
3								
4	Free stopping	Free-run						
5	Dynamic braking	Free-run						

Pr5.11	Label	Servo braking torque setting			Mode	P	V	T
	Range	0~500	Unit	%	Default	0	Index	2511h
	Activation	Immediate						
<p>To set torque limit for servo braking mode. If Pr5.11 = 0, use torque limit as under normal situation. Between max. torque 6072 and Pr5.11, actual torque limit will take smaller value.</p>								

Pr5.12	Label	Overload level setting			Mode	P	V	T
	Range	0~115	Unit	%	Default	0	Index	2512h
	Activation	Immediate						
<p>If Pr5.12 = 0, overload level = 115% Use only when overload level degradation is needed.</p>								

Pr5.13	Label	Overspeed level settings			Mode	P	V	T
	Range	0~10000	Unit	RPM	Default	0	Index	2513h
	Activation	Immediate						
<p>If motor speed exceeds Pr5.13, Er1A0 might occur. When Pr5.13 = 0, overspeed level = max. motor speed x 1.2</p>								

Pr5.15	Label	I/O digital filter			Mode	P	V	T
	Range	0~255	Unit	0.1ms	Default	10	Index	2515h
	Activation	Immediate						
<p>Digital filtering of I/O input. Overly large value set will cause control delay.</p>								

Pr5.17	Label	Counter clearing input mode			Mode	P										
	Range	0~4	Unit	-	Default	3	Index	2515h								
	Activation	Immediate														
<p>To set the clearing conditions for deviation counter clearing input signal.</p> <table border="1"> <thead> <tr> <th>Set value</th> <th>Condition</th> </tr> </thead> <tbody> <tr> <td>0/2/4</td> <td>Invalid</td> </tr> <tr> <td>1</td> <td>Always clear</td> </tr> <tr> <td>3</td> <td>Clear only once</td> </tr> </tbody> </table>									Set value	Condition	0/2/4	Invalid	1	Always clear	3	Clear only once
Set value	Condition															
0/2/4	Invalid															
1	Always clear															
3	Clear only once															

Pr5.20	Label	Position unit settings			Mode	P		
	Range	0~2	Unit	—	Default	2	Index	2520h
	Activation	Disable						

Set value	Unit
0	Encoder unit
1	Command unit
2	0.0001rev

Command unit: Pulse from host
Encoder unit: Pulse from encoder
Pr5.20 only changes the unit use on host tracing function, has no relation with any position related parameters.

Pr5.21	Label	Torque limit selection			Mode	P	V	T
	Range	0~2	Unit	—	Default	2	Index	2521h
	Activation	Immediate						

Set value	Positive limit value	Negative limit value
0	Pr0.13	Pr0.13
1	Pr0.13	Pr5.22
2	60E0	60E1

Between max. torque 6072 and Pr5.21, actual torque limit will take smaller value.

Pr5.22	Label	2 nd torque limit			Mode	P	V	T
	Range	0~500	Unit	%	Default	300	Index	2522h
	Activation	Immediate						

Limited by motor max. torque.
Between max. torque 6072 and Pr5.22, actual torque limit will take smaller value.

Pr5.23	Label	Positive torque warning threshold			Mode	P	V	T
	Range	0~300	Unit	%	Default	0	Index	2523h
	Activation	Immediate						

If Pr5.23 = 0, threshold value = 95%
If torque larger than rated torque, then output = Torque command limit

Pr5.24	Label	Negative torque warning threshold			Mode	P	V	T
	Range	0~300	Unit	%	Default	0	Index	2524h
	Activation	Immediate						

If Pr5.24 = 0, threshold value = 95%
If torque smaller than rated torque, then output = Torque command limit

Pr5.28	Label	LED initial status			Mode	P	V	T
	Range	0~42	Unit	–	Default	34	Index	2528h
	Activation	After restart						

To set content display on front panel of the servo driver at servo driver power on.

Set value	Content	Set value	Content	Set value	Content
0	Position command deviation	15	Overload rate	30	No. of encoder communication error
1	Motor speed	16	Inertia ratio	31	Accumulated operation time
2	Position command velocity	17	No rotation cause	32	Automatic motor identification
3	Velocity control command	18	No. of changes in I/O signals	33	Driver temperature
4	Actual feedback torque	19	Number of over current signals	34	Servo status
5	Sum of feedback pulse	20	Absolute encoder data	35	/
6	Sum of command pulse	21	Single turn position	36	Synchronous period
7	Maximum torque during motion	22	Multiturn position	37	No. of synchronous loss
8	/	23	Communication axis address	38	Synchronous type
9	Control mode	24	Encoder position deviation	39	Whether DC is running or not
10	I/O signal status	25	Motor electrical angle	40	Acceleration/Deceleration status
11	/	26	Motor mechanical Angle	41	Sub-index of OD index
12	Error cause and history record	27	Voltage across PN	42	Value of sub-index of OD index
13	Alarm code	28	Software version		
14	Regenerative load rate	29	/		

Pr5.32	Label	Max. command pulse input frequency			Mode	P		
	Range	0~4000	Unit	kHz	Default	0	Index	2532h
	Activation	Immediate						
If command pulse input frequency exceeds Pr5.32, Er1B0 might occur. Default = 0, 550kHz								

Pr5.35	Label	Front panel lock setting			Mode	P	V	T
	Range	0~1	Unit	-	Default	0	Index	2535h
	Activation	Immediate						
Lock operation on the front panel.								
		Set value	Explanation					
		0	No limit on the front panel operation					
		1	Lock operation on the front panel					

Pr5.37	Label	Torque limit duration during initialization			Mode	P	V	T
	Range	0~5000	Unit	ms	Default	500	Index	2537h
	Activation	Immediate						
To set time threshold for output torque to reach limit under torque initialization mode. Only applicable for torque initialization method -6 to -1 Under torque initialization mode, motor torque reached Pr5.39 and the duration reaches Pr5.37 before moving into next step.								

Pr5.39	Label	3 rd torque limit			Mode	P	V	T
	Range	0~500	Unit	%	Default	80	Index	2539h
	Activation	Immediate						
To set torque limit during torque initialization Between max. torque 6072 and Pr5.22, actual torque limit will take smaller value.								

Pr5.40	Label	D41 set value			Mode	P	V	T
	Range	0x0~0xFFFFF	Unit	%	Default	0X30C	Index	2540h
	Activation	Immediate						
Set object word monitored by D41, index (left 4 bits) + sub-index (right 1 bit), if monitoring 0x6092-01, set Pr5.40 to 0x60921.								

【Class 6】 Other settings

Pr6.01	Label	Encoder zero position compensation			Mode	P	V	T
	Range	0~360	Unit	°	Default	0	Index	2601h
	Activation	After restart						
Angle of the encoder after zero position calibration								

Pr6.04	Label	JOG trial run velocity command			Mode	P		
	Range	0~10000	Unit	r/min	Default	400	Index	2604h
	Activation	Immediate						
To set velocity for JOG trial run command.								

Pr6.05	Label	Position 3 rd gain valid time			Mode	P		
	Range	0~10000	Unit	0.1ms	Default	0	Index	2605h
	Activation	Immediate						
To set time for 3 rd gain to be valid When not in use, set Pr6.05=0, Pr6.06=100								

Pr6.06	Label	Position 3 rd gain scale factor			Mode	P		
	Range	0~1000	Unit	100%	Default	100	Index	2606h
	Activation	Immediate						

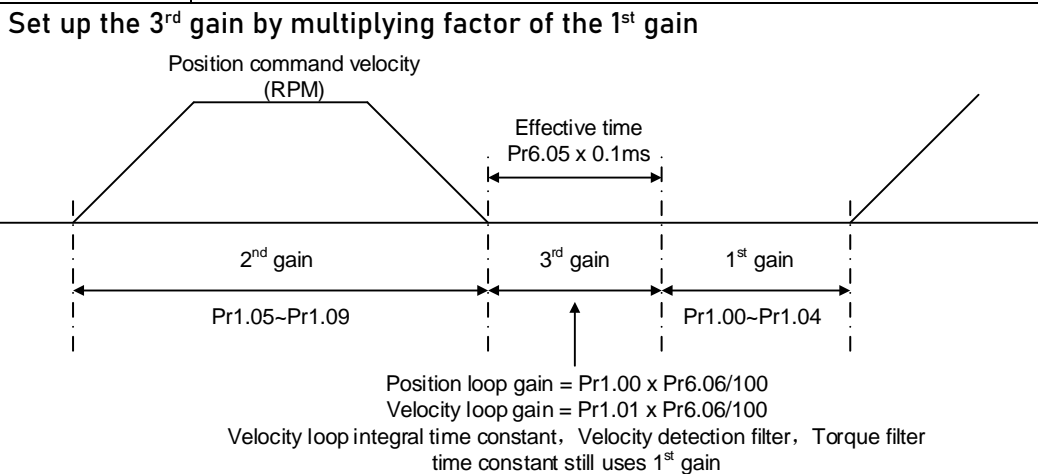

3rd gain = 1st gain * Pr6.06/100

Only effective under position control mode, set Pr6.05 ≠ 0, 3rd gain function activated, set 3rd gain value in Pr6.06. When 2nd gain switches to 1st gain, will go through 3rd, switching time value set in Pr1.19.

Above diagram is illustrated using Pr1.15 = 7.

Pr6.07	Label	Torque command additional value			Mode	P	V	T
	Range	-100~100	Unit	%	Default	0	Index	2607h
	Activation	Immediate						
<p>To set torque forward feed additional value of vertical axis. Applicable for loaded vertical axis, compensate constant torque. Application: When load move along vertical axis, pick any point from the whole motion and stop the load at that particular point with motor enabled but not rotating. Record output torque value from d04, use that value as torque command additional value (compensation value)</p>								

Pr6.08	Label	Positive direction torque compensation value			Mode	P	V	T
	Range	-100~100	Unit	%	Default	0	Index	2608h
	Activation	Immediate						
Pr6.09	Label	Negative direction torque compensation value			Mode	P	V	T
	Range	-100~100	Unit	%	Default	0	Index	2609h
	Activation	Immediate						
<p>To reduce the effect of mechanical friction in the movement(s) of the axis. Compensation values can be set according to needs for both rotational directions.</p> <p>Applications: 1. When motor is at constant speed, d04 will deliver torque values. Torque value in positive direction = T1; Torque value in negative direction = T2</p> $\text{Pr6.08/Pr6.09} = T_f = \frac{ T1 - T2 }{2}$								

Pr6.11	Label	Current response settings			Mode	P	V	T
	Range	50~100	Unit	%	Default	100	Index	2611h
	Activation	Immediate						
To set driver current loop related effective value ratio								

Pr6.14	Label	Max. time to stop after disabling			Mode	P	V	T
	Range	0~3000	Unit	ms	Default	500	Index	2614h
	Activation	Immediate						

To set the max. time allowed for the axis to stop on emergency stop or normal axis disabling.
 After disabling axis, if motor speed is still higher than Pr4.39 but the time set in Pr6.14 is reached, BRK_ON given and holding brake activated.
 BRK_ON given time is determined by Pr6.14 or when motor speed goes below Pr4.39, whichever comes first.

Applications:

1. After disabling axis, if motor speed is still higher than Pr4.39 but the time set in Pr6.14 is reached, BRK_ON given and holding brake activated.
2. After disabling axis, if motor speed is already lower than Pr4.39 but the time set in Pr6.14 is not yet reached, BRK_ON given and holding brake activated.

Pr6.20	Label	Trial run distance			Mode	P		
	Range	0~1200	Unit	0.1rev	Default	10	Index	2620h
	Activation	Immediate						
JOG (Position control) : Distance travel of each motion								

Pr6.21	Label	Trial run waiting time			Mode	P		
	Range	0~30000	Unit	ms	Default	300	Index	2621h
	Activation	Immediate						
JOG (Position control) : Waiting time after each motion								

Pr6.22	Label	No. of trial run cycles			Mode	P		
	Range	0~32767	Unit	PCS	Default	5	Index	2622h
	Activation	Immediate						
JOG (Position control) : No. of cycles								

Pr6.25	Label	Trial run acceleration			Mode	P	V	
	Range	0~10000	Unit	ms/(1000rpm)	Default	200	Index	2625h
	Activation	Immediate						
To set the acceleration/deceleration time for JOG command between 0 rpm to 1000 rpm								

Pr6.28	Label	Velocity observer gain			Mode	P	V	T
	Range	0~32767	Unit	—	Default	0	Index	2628h
	Activation	Immediate						
0: Default stable gain; Modifications are not recommended.								

Pr6.29	Label	Velocity observer bandwidth			Mode	P	V	T
	Range	0~32767	Unit	ms	Default	0	Index	2629h
	Activation	Immediate						
0: Default stable bandwidth; Modifications are recommended.								

Pr6.34	Label	Frame error window time			Mode	P	V	T
	Range	0~32767	Unit	ms	Default	100	Index	2634h
	Activation	Immediate						
To set EtherCAT data frame error detection window time								

Pr6.35	Label	Frame error window			Mode	P	V	T
	Range	0~32767	Unit	-	Default	50	Index	2635h
	Activation	Immediate						
To set EtherCAT data frame error detection window								

Pr6.54	Label	Absolute value rotation mode denominator setting			Mode	P		
	Range	0~32766	Unit	-	Default	0	Index	2654h
	Activation	After restart						
<p>To set denominator of absolute encoder in rotational mode. When Pr0.15 = 2 and use in combination with Pr6.54: Feedback load position $6064 = \frac{\text{Pr6.63}}{\text{Pr6.54}} \times \text{Electronic gear ratio}$</p>								

Pr6.56	Label	Blocked rotor alarm torque threshold			Mode	P	V	T
	Range	0~300	Unit	%	Default	300	Index	2656h
	Activation	Immediate						
<p>To set the torque threshold of blocked rotor to trigger alarm. (Alarm triggered if torque output% larger than threshold value & under 10rpm) If Pr6.56 = 0, blocked rotor alarm deactivated. (This applicable only to 220VAC drivers) If motor speed is 10rpm or above, Er102 won't be triggered.</p>								

Pr6.57	Label	Blocked rotor alarm delay time			Mode	P	V	T
	Range	0~1000	Unit	ms	Default	400	Index	2657h
	Activation	Immediate						
To set delay time for blocked rotor alarm to trigger								

Pr6.59	Label	Homing mode position threshold			Mode	P	V	T
	Range	0~100	Unit	0.00001rev	Default	5	Index	2659h
	Activation	Immediate						
To set position threshold for homing mode.								

Pr6.61	Label	Z signal holding time			Mode	P	V	T
	Range	0~100	Unit	ms	Default	10	Index	2661h
	Activation	Immediate						
<p>To set the holding time for Z signal to maintain active high</p> <p>Application:</p> <ol style="list-style-type: none"> 1. Z signal for 60FDH; 2. Z signal for homing process 3. Z-phase frequency output pulse width. Unit = 0.1ms; <p>Please set $Pr6.61 \geq 0.2ms$ if used for 3 applications as above</p>								

Pr6.63	Label	Absolute multiturn data upper limit			Mode	P	V	T
	Range	0~32766	Unit	rev	Default	0	Index	2663h
	Activation	After restart						
<p>To set upper limit of multiturn data with absolute encoder set as rotational mode.</p> <p>When $Pr0.15 = 2$ and use in combination with Pr6.54:</p> $\text{Feedback load position } 6064 = \frac{Pr6.63}{Pr6.54} \times \text{Electronic gear ratio}$								

402 Parameters Function

Parameter Valid mode Description

P: Position control mode

V: Velocity control mode

T: Torque control mode

Index 603Fh	Label	Error code			Unit	-	Structure	VAR	Type	Uint 16
	Access	RO	Mapping	TPDO	Mode	P/V/T	Range	0x0~0 xFFFF	Default	0X0
Please refer to Chapter 9 for more details on error codes.										

Index 6040h	Label	Control word			Unit	-	Structure	VAR	Type	Uint 16																																	
	Access	RW	Mapping	RPDO	Mode	P/V/T	Range	0x0- 0xFFFF F	Default	0X0																																	
<table border="1"> <thead> <tr> <th>Bit</th> <th>Label</th> <th>Description</th> </tr> </thead> <tbody> <tr> <td>0</td> <td>Start</td> <td>1 - valid, 0 - invalid</td> </tr> <tr> <td>1</td> <td>Main circuit power on</td> <td>1 - valid, 0 - invalid</td> </tr> <tr> <td>2</td> <td>Quick stop</td> <td>0 - valid, 1 - invalid</td> </tr> <tr> <td>3</td> <td>Servo running</td> <td>1 - valid, 0 - invalid</td> </tr> <tr> <td>4-6</td> <td>Running mode related</td> <td>Related to each servo running mode</td> </tr> <tr> <td>7</td> <td>Fault reset</td> <td>Reset resettable fault alarm. Rising edge of Bit7 is valid, bit7 remains at 1, and all other instructions are invalid</td> </tr> <tr> <td>8</td> <td>Pause</td> <td>For more information on how to pause in each mode, refer to Object Dictionary 605Dh</td> </tr> <tr> <td>9</td> <td>No definition</td> <td>Undefined</td> </tr> <tr> <td>10</td> <td>Reserved</td> <td>Undefined</td> </tr> <tr> <td>11-15</td> <td>Reserved</td> <td>Undefined</td> </tr> </tbody> </table>											Bit	Label	Description	0	Start	1 - valid, 0 - invalid	1	Main circuit power on	1 - valid, 0 - invalid	2	Quick stop	0 - valid, 1 - invalid	3	Servo running	1 - valid, 0 - invalid	4-6	Running mode related	Related to each servo running mode	7	Fault reset	Reset resettable fault alarm. Rising edge of Bit7 is valid, bit7 remains at 1, and all other instructions are invalid	8	Pause	For more information on how to pause in each mode, refer to Object Dictionary 605Dh	9	No definition	Undefined	10	Reserved	Undefined	11-15	Reserved	Undefined
Bit	Label	Description																																									
0	Start	1 - valid, 0 - invalid																																									
1	Main circuit power on	1 - valid, 0 - invalid																																									
2	Quick stop	0 - valid, 1 - invalid																																									
3	Servo running	1 - valid, 0 - invalid																																									
4-6	Running mode related	Related to each servo running mode																																									
7	Fault reset	Reset resettable fault alarm. Rising edge of Bit7 is valid, bit7 remains at 1, and all other instructions are invalid																																									
8	Pause	For more information on how to pause in each mode, refer to Object Dictionary 605Dh																																									
9	No definition	Undefined																																									
10	Reserved	Undefined																																									
11-15	Reserved	Undefined																																									

Index 6041h	Label	Status word			Unit	-	Structure	VAR	Type	Uint 16
	Access	RO	Mapping	TPDO	Mode	P/V/T	Range	0x0~ 0xFF FF	Default	0x0
	Bit	Label			Description					
	0	Servo ready			1 - valid, 0 - invalid					
	1	Start			1 - valid, 0 - invalid					
	2	Servo running			1 - valid, 0 - invalid					
	3	Fault			1 - valid, 0 - invalid					
	4	Main circuit power on			1 - valid, 0 - invalid					
	5	Quick stop			0- valid, 1 - invalid					
	6	Servo cannot run			1 - valid, 0 - invalid					
	7	Warning			1 - valid, 0 - invalid					
	8	Reserved			Reserved					
	9	Remote control			1 - valid, 0 - invalid					
	10	Arrived at position			1 - valid, 0 - invalid					
	11	Internal limit valid			1 - valid, 0 - invalid					
	12-13	Mode related			Related to each servo operation mode					
	14	Reserved			Reserved					
	15	Origin found			1 - valid, 0 - invalid					

Index 605Ah	Label	Quick stop option code			Unit	-	Structure	VAR	Type	INT 16
	Access	RW	Mapping	-	Mode	P/V/T	Range	0~7	Default	2
	Motor stops when quick stop command is given.									
	PP, CSP, CSV, PV									
	0 : To stop motor through Pr5.06. Status: Switch on disable, axis disabled.									
	1 : Motor decelerates and stops through 6084. Status: Switch on disable, axis disabled.									
	2 : Motor decelerates and stops through 6085. Status: Switch on disable, axis disabled.									
	3 : Motor decelerates and stops through 60C6. Status: Switch on disable, axis disabled.									
	5 : Motor decelerates and stops through 6084. Status: Quick stop									
	6 : Motor decelerates and stops through 6085. Status: Quick stop									
	7 : Motor decelerates and stops through 60C6. Status: Quick stop									
	HM									
	0 : To stop motor through Pr5.06. Status: Switch on disable, axis disabled.									
	1 : Motor decelerates and stops through 609A. Status: Switch on disable, axis disabled.									
	2 : Motor decelerates and stops through 6085. Status: Switch on disable, axis disabled.									
	3 : Motor decelerates and stops through 60C6. Status: Switch on disable, axis disabled.									
	5 : Motor decelerates and stops through 609A. Status: Quick stop									
	6 : Motor decelerates and stops through 6085. Status: Quick stop									
	7 : Motor decelerates and stops through 60C6. Status: Quick stop									

CST

- 0 : To stop motor through Pr5.06. Status: Switch on disable, axis disabled.
- 1, 2 : Motor decelerates and stops through 6087. Status: Switch on disable, axis disabled.
- 3 : Motor decelerates and stops through torque = 0. Status: Switch on disable, axis disabled.
- 5, 6 : Motor decelerates and stops through 6087. Status: Quick stop
- 7 : Motor decelerates and stops through torque = 0. Status: Quick stop

Index 605Bh	Label	Motor deceleration-stopping mode selection			Mode	P	V	T
	Range	RW	Unit	-	Range	0~1	Default	0
PP, CSP, CSV, PV 0 : To stop motor through Pr5.06, 5.06 = 0(Emergency stop), 5.06=1(Free stop) 1 : Motor decelerates and stops through 6084 HM 0 : To stop motor through Pr5.06, 5.06 = 0(Emergency stop), 5.06=1(Free stop) 1 : Motor decelerates and stops through 609A CST 0 : To stop motor through Pr5.06, 5.06 = 0(Emergency stop), 5.06=1(Free stop) 1 : Motor decelerates and stops through 6087								

Index 605Ch	Label	Axis disabled-stopping mode selection			Mode	P	V	T
	Range	RW	Unit	-	Range	0~1	Default	0
PP, CSP, CSV, PV 0 : To stop motor through Pr5.06, 5.06 = 0(Emergency stop), 5.06=1(Free stop) 1 : Motor decelerates and stops through 6084 HM 0 : To stop motor through Pr5.06, 5.06 = 0(Emergency stop), 5.06=1(Free stop) 1 : Motor decelerates and stops through 609A CST 0 : To stop motor through Pr5.06, 5.06 = 0(Emergency stop), 5.06=1(Free stop) 1 : Motor decelerates and stops through 6087								

Index 605Dh	Label	Pause-stopping mode selection			Unit	-	Structure	VAR	Type	INT 16
	Access	RW	Mapping	-	Mode	P/V/T	Range	1~3	Default	1
<p>When control word – pause sets decelerating, stopping mode. Also suitable for deceleration mode settings during mode switching</p> <p>PP, CSP, CSV, PV</p> <p>1 : Motor decelerates and stops through 6084. Status: Operation enabled, axis enabled.</p> <p>2 : Motor decelerates and stops through 6085. Status: Operation enabled, axis enabled.</p> <p>3 : Motor decelerates and stops through 60C6. Status: Operation enabled, axis enabled.</p> <p>HM</p> <p>1 : Motor decelerates and stops through 609A. Status: Operation enabled, axis enabled.</p> <p>2 : Motor decelerates and stops through 6085. Status: Operation enabled, axis enabled.</p> <p>3 : Motor decelerates and stops through 60C6. Status: Operation enabled, axis enabled.</p> <p>CST</p> <p>1, 2 : Motor decelerates and stops through 6087. Status: Operation enabled, axis enabled.</p> <p>3 : Motor decelerates and stops through torque = 0. Status: Operation enabled, axis enabled.</p>										

Index 605Eh	Label	Alarm - stopping mode selection			Unit	-	Structure	VAR	Type	INT 16
	Access	RW	Mapping	-	Mode	P/V/T	Range	0~2	Default	0
<p>Select stopping mode when servo alarm (Err 8xx) occurs.</p> <p>PP, CSP, CSV, PV</p> <p>0 : Select motor stopping mode according to alarm properties. Status: Fault, axis disabled.</p> <p>1 : Motor decelerates and stops through 6084. Status: Fault, axis disabled.</p> <p>2 : Motor decelerates and stops through 6085. Status: Fault, axis disabled.</p> <p>HM</p> <p>0 : Select motor stop by the alarm attribute for emergency stop, the fault state and disable</p> <p>1 : After the 609A motor is decelerated and stopped,, the fault state and disable</p> <p>2 : After the 6085 motor is decelerated and stopped, the fault state and disable</p> <p>CST</p> <p>0, 1 : Select motor stop by the alarm attribute for emergency stop, the fault state and disable</p> <p>2 : After the 6087 motor is decelerated and stopped, the fault state and disable</p> <p>When other alarms, i.e. drive-side alarms:</p> <p>Select motor stop by the alarm attribute for emergency stop, the fault state and disable</p>										

Index 6060h	Label	Operation mode selection			Unit	-	Structure	VAR	Type	Int 8																								
	Access	RW	Mapping	RPDO	Mode	P/V/T	Range	1~11	Default	8																								
<table border="1"> <thead> <tr> <th>No.</th> <th>Mode</th> <th>Abbr.</th> </tr> </thead> <tbody> <tr> <td>1</td> <td>Profile position mode</td> <td>PP</td> </tr> <tr> <td>3</td> <td>Profile velocity mode</td> <td>PV</td> </tr> <tr> <td>4</td> <td>profile Torque mode</td> <td>PT</td> </tr> <tr> <td>6</td> <td>Homing mode</td> <td>HM</td> </tr> <tr> <td>8</td> <td>Cyclic synchronous position mode</td> <td>CSP</td> </tr> <tr> <td>9</td> <td>Cyclic synchronous velocity mode</td> <td>CSV</td> </tr> <tr> <td>10</td> <td>Cyclic synchronous torque mode</td> <td>CST</td> </tr> </tbody> </table>											No.	Mode	Abbr.	1	Profile position mode	PP	3	Profile velocity mode	PV	4	profile Torque mode	PT	6	Homing mode	HM	8	Cyclic synchronous position mode	CSP	9	Cyclic synchronous velocity mode	CSV	10	Cyclic synchronous torque mode	CST
No.	Mode	Abbr.																																
1	Profile position mode	PP																																
3	Profile velocity mode	PV																																
4	profile Torque mode	PT																																
6	Homing mode	HM																																
8	Cyclic synchronous position mode	CSP																																
9	Cyclic synchronous velocity mode	CSV																																
10	Cyclic synchronous torque mode	CST																																

Index 6061h	Label	Operation mode display			Unit	-	Structure	VAR	Type	Int 8																								
	Access	RW	Mapping	RPDO	Mode	P/V/T	Range	1~11	Default	8																								
<table border="1"> <thead> <tr> <th>No.</th> <th>Mode</th> <th>Abbr.</th> </tr> </thead> <tbody> <tr> <td>1</td> <td>Profile position mode</td> <td>PP</td> </tr> <tr> <td>3</td> <td>Profile velocity mode</td> <td>PV</td> </tr> <tr> <td>4</td> <td>profile Torque mode</td> <td>PT</td> </tr> <tr> <td>6</td> <td>Homing mode</td> <td>HM</td> </tr> <tr> <td>8</td> <td>Cyclic synchronous position mode</td> <td>CSP</td> </tr> <tr> <td>9</td> <td>Cyclic synchronous velocity mode</td> <td>CSV</td> </tr> <tr> <td>10</td> <td>Cyclic synchronous torque mode</td> <td>CST</td> </tr> </tbody> </table>											No.	Mode	Abbr.	1	Profile position mode	PP	3	Profile velocity mode	PV	4	profile Torque mode	PT	6	Homing mode	HM	8	Cyclic synchronous position mode	CSP	9	Cyclic synchronous velocity mode	CSV	10	Cyclic synchronous torque mode	CST
No.	Mode	Abbr.																																
1	Profile position mode	PP																																
3	Profile velocity mode	PV																																
4	profile Torque mode	PT																																
6	Homing mode	HM																																
8	Cyclic synchronous position mode	CSP																																
9	Cyclic synchronous velocity mode	CSV																																
10	Cyclic synchronous torque mode	CST																																

Index 6062h	Label	Position command			Unit	Command unit	Structure	VAR	Type	Int 32
	Access	R0	Mapping	TPDO	Mode	P	Range	- 2147483648 ~2147483647	Default	0
Reflects position command when servo driver is enabled.										

Index 6063h	Label	Actual internal position			Unit	Encoder unit	Structure	VAR	Type	Int 32
	Access	R0	Mapping	TPDO	Mode	P/V/T	Range	- 2147483648 ~2147483647	Default	0
Reflects motor absolute position (Encoder unit)										

Index 6064h	Label	Actual position feedback			Unit	Command unit	Structure	VAR	Type	Int 32
	Access	R0	Mapping	TPDO	Mode	P/V/T	Range	- 2147483648 ~2147483647	Default	0
Reflects user's real time absolute position 6064h*Gear ratio = 6063h										

Index 6065h	Label	Position deviation window			Unit	Command unit	Structure	VAR	Type	UInt 32
	Access	R0	Mapping	TPDO	Mode	P	Range	0~2147483647	Default	0
To set an acceptable deviation for requested position. When actual position exceed position deviation window, error might occur.										

Index 6066h	Label	Position deviation detection time			Unit	ms	Structure	VAR	Type	UInt 16
	Access	R0	Mapping	TPDO	Mode	P	Range	0~65535	Default	0
To set position deviation detection time										

Index 6067h	Label	Position window			Unit	Command unit/s	Structure	VAR	Type	UInt 32
	Access	R0	Mapping	TPDO	Mode	P	Range	0~2147483647	Default	0
To set an acceptable extent of arrival position										

Index 6068h	Label	Position window time			Unit	Command unit/s	Structure	VAR	Type	UInt 16
	Access	R0	Mapping	TPDO	Mode	P	Range	0~65535	Default	0
To set the time between arrival to the output of INP (In position) signal.										

Index 606Bh	Label	Internal command velocity			Unit	Command unit/s	Structure	VAR	Type	Int 32
	Access	R0	Mapping	TPDO	Mode	P/V/T	Range	- 2147483648~ 2147483647	Default	0
To set the time between arrival to the output of INP (In position) signal.										

Index 606Ch	Label	Velocity feedback			Unit	Command unit/s	Structure	VAR	Type	Int 32
	Access	R0	Mapping	TPDO	Mode	P/V	Range	- 2147483648~ 2147483647	Default	0
Reflects user's internal command velocity feedback value										

Index 606Dh	Label	Velocity window			Unit	Command unit/s	Structure	VAR	Type	UInt 16
	Access	R0	Mapping	RPDO	Mode	V	Range	0~65535	Default	10
Set the range of velocity										

Index 606Eh	Label	Velocity window time			Unit	ms	Structure	VAR	Type	UInt 16
	Access	R0	Mapping	RPDO	Mode	V	Range	0~65535	Default	0
To set the time between velocity reached and status word set to TargetReached.										

Index 606Fh	Label	Zero-speed threshold			Unit	Command unit/s	Structure	VAR	Type	UInt 16
	Access	R0	Mapping	RPDO	Mode	V	Range	0~65535	Default	10
To set to zero-speed threshold.										

Index 6070h	Label	Zero-speed threshold time			Unit	ms	Structure	VAR	Type	UInt 16
	Access	R0	Mapping	RPDO	Mode	V	Range	0~65535	Default	100
To set the time until status word – zero speed detection is canceled.										

Index 6071h	Label	Target torque			Unit	0.1%	Structure	VAR	Type	UInt 16
	Access	RW	Mapping	RPDO	Mode	T	Range	- 32768~ 32767	Default	0
To set target torque for protocol and cyclic torque mode.										

Index 6072h	Label	Maximum torque			Unit	0.1%	Structure	VAR	Type	UInt 16
	Access	RW	Mapping	RPDO	Mode	P/V/T	Range	0~65535	Default	3000
To set max. torque for servo driver. Limited by motor max. torque.										

Index 6073h	Label	Maximum current			Unit	0.1%	Structure	VAR	Type	UInt 16
	Access	R0	Mapping	TPDO	Mode	P/V/T	Range	0~65535	Default	3000
To set max. current for servo driver.										

Index 6074h	Label	Internal command torque			Unit	0.1%	Structure	VAR	Type	Int 16
	Access	R0	Mapping	TPDO	Mode	P/V/T	Range	-32768~32767	Default	0
Internal command torque										

Index 6075h	Label	Motor current rating			Unit	mA	Structure	VAR	Type	Int 32
	Access	R0	Mapping	TPDO	Mode	P/V/T	Range	0~2147483647	Default	3000
Shows motor rated current.										

Index 6077h	Label	Actual torque			Unit	0.1%	Structure	VAR	Type	Int 16
	Access	R0	Mapping	TPDO	Mode	P/V/T	Range	-32768~32767	Default	0
Shows servo driver actual torque feedback										

Index 6079h	Label	DC bus voltage			Unit	mV	Structure	VAR	Type	UInt 32
	Access	R0	Mapping	TPDO	Mode	P/V/T	Range	0~2147483647	Default	0
Shows DC bus voltage across P, N terminals										

Index 607Ah	Label	Target position			Unit	Command unit	Structure	VAR	Type	Int 32
	Access	RW	Mapping	TPDO	Mode	P	Range	-2147483647~2147483647	Default	0
To set the target position under protocol and cyclic position mode.										

Index 607Ch	Label	Homing position offset			Unit	Command unit	Structure	VAR	Type	Int 32
	Access	R W	Mapping	TPDO	Mode	P	Range	- 2147483647 ~214748364 7	Default	0
To set position offset to compensate for the deviation of mechanical origin from motor origin under homing										

Index 607Dh-01	Label	Min. software limit			Unit	Command unit	Structure	VAR	Type	Int 32
	Access	RW	Mapping	TPDO	Mode	P	Range	- 2147483647~ 2147483647	Default	0
To set lower limit with calculated position and actual position using absolute position after homing.										

Index 607Dh-02	Label	Max. software limit			Unit	Command unit	Structure	VAR	Type	Int 32
	Access	RW	Mapping	TPDO	Mode	P	Range	- 2147483647~ 2147483647	Default	0
To set upper limit with calculated position and actual position using absolute position after homing.										

Index 607Eh	Label	Motor rotational direction			Unit	-	Structure	VAR	Type	UInt 8
	Access	RW	Mapping	RPDO	Mode	P	Range	0x0 – 0xFF	Default	0x0

Mode		Value
Position mode	PP	0: Rotate in the same direction as the position command
	HM	128: Rotate in the opposite direction to the position command
	CSP	
Velocity mode	PV	0: Rotate in the same direction as the position command
	CSV	64: Rotate in the opposite direction to the position command
Torque mode	PT	0: Rotate in the same direction as the position command
	CST	32: Rotate in the opposite direction to the position command
ALL mode		0: Rotate in the same direction as the position command 224: Rotate in the opposite direction to the position command

Sets the input polarity of the command.

Index 607Fh	Label	Maximum protocol velocity			Unit	Command unit/s	Structure	VAR	Type	UInt 32
	Access	R W	Mapping	RPDO	Mode	P/V/T	Range	0~214 74836 47	Default	21474836 47
To set maximum allowable velocity. Limited by 6080.										

Index 6080h	Label	Maximum motor velocity			Unit	R/min	Structure	VAR	Type	UInt 32
	Access	R W	Mapping	RPDO	Mode	P/V/T	Range	0~214 74836 47	Default	6000
To set the maximum allowable motor velocity.										

Index 6081h	Label	Protocol velocity			Unit	Command unit/s	Structure	VAR	Type	UInt 32
	Access	R W	Mapping	RPDO	Mode	P	Range	0~214 74836 47	Default	10000
To set target velocity. Limited by 607Fh.										

Index 6083h	Label	Protocol acceleration			Unit	Command unit/s ²	Structure	VAR	Type	UInt 32
	Access	R W	Mapping	RPDO	Mode	P/V	Range	1~214 74836 47	Default	10000
To set motor acceleration										

Index 6084h	Label	Protocol deceleration			Unit	Command unit/s ²	Structure	VAR	Type	UInt 32
	Access	R W	Mapping	RPDO	Mode	P/V	Range	1~214 74836 47	Default	10000000
To set motor deceleration										

Index 6085h	Label	Emergency stop deceleration			Unit	Command unit/s ²	Structure	VAR	Type	UInt 32
	Access	R W	Mapping	RPDO	Mode	P/V	Range	1~214 74836 47	Default	10000
To set the deceleration during an emergency stop										

Index 6087h	Label	Torque slope			Unit	%1/s	Structure	VAR	Type	UInt 32
	Access	R W	Mapping	RPDO	Mode	PT	Range	1~214 74836 47	Default	5000
To set values for tendency torque command										

Index 608Fh- 01	Label	Encoder resolution			Unit	Encoder unit	Structure	VAR	Type	UInt 32
	Access	R 0	Mapping	TPDO	Mode	P/V/T	Range	1~214 74836 47	Default	0
To set encoder resolution										

Index 6091h-01	Label	Electronic gear ratio numerator			Unit	r	Structure	VAR	Type	Dint 32
	Access	RW	Mapping	RPDO	Mode	P/V/T	Range	1- 214748 3647	Default	1
To set electronic gear ratio numerator										

Index 6091h-02	Label	Electronic gear ratio denominator			Unit	r	Structure	VAR	Type	Dint 32
	Access	RW	Mapping	RPDO	Mode	P/V/T	Range	1- 214748 3647	Default	1
To set electronic gear ratio denominator										

Index 6092h-01	Label	Number of pulses per rotation			Unit	Comman d unit/r	Structure	VAR	Type	UInt 32
	Access	RW	Mapping	RPDO	Mode	P/V/T	Range	1~21474 83647	Default	10000
<p>If 6092h-01(Feed constant) is not equal to 608Fh(Position encoder resolution), then: Electronic gear ratio = Encoder resolution / 6092h-01</p> <p>If 6092h-01(Feed constant) is equal to 608Fh(Position encoder resolution), then: Electronic gear ratio = 6091-01 / 6092h-01</p>										

Index 6098h	Label	Homing method			Unit	-	Structure	VAR	Type	UInt 8
	Access	RW	Mapping	RPDO	Mode	P/V/ T	Range	-6- 37	Default	19
	The table below describes the velocity, direction and stopping conditions of each homing methods.									
	Ref no.	Description								
		Velocity	Direction	Stop						
	-6	Low	Negative	When torque reached						
	-5	Low	Positive	When torque reached						
	-4	High	Negative	Inversed when torque reached, after torque is gone						
	-3	High	Positive	Inversed when torque reached, after torque is gone						
	-2	High	Negative	Inversed when torque reached, received 1 st Z-signal after torque is gone						
	-1	High	Positive	Inversed when torque reached, received 1 st Z-signal after torque is gone						
		Direction	Deceleration point	Home	Before Z-signal					
	1	Negative	Negative limit switch	Motor Z-signal	Negative limit switch falling edge					
	2	Positive	Positive limit switch	Motor Z-signal	Positive limit switch falling edge					
	3	Positive	Homing switch	Motor Z-signal	Falling edge on same side of homing switch					
	4	Positive	Homing switch	Motor Z-signal	Rising edge on same side of homing switch					
	5	Negative	Homing switch	Motor Z-signal	Falling edge on same side of homing switch					
	6	Negative	Homing switch	Motor Z-signal	Rising edge on same side of homing switch					
	7	Positive	Homing switch	Motor Z-signal	Falling edge on same side of homing switch					
	8	Positive	Homing switch	Motor Z-signal	Rising edge on same side of homing switch					
	9	Positive	Homing switch	Motor Z-signal	Rising edge on same side of homing switch					
	10	Positive	Homing switch	Motor Z-signal	Falling edge on same side of homing switch					
	11	Negative	Homing switch	Motor Z-signal	Falling edge on same side of homing switch					
	12	Negative	Homing switch	Motor Z-signal	Rising edge on same side of homing switch					
	13	Negative	Homing switch	Motor Z-signal on other side of homing switch	Rising edge on other side of homing switch					
	14	Negative	Homing switch	Motor Z-signal on other side of homing switch	Falling edge on other side of homing switch					

	15	
	16	
	17-32	Similar with 1-14, but deceleration point = homing point
	33	Home in negative direction, Homing point = motor Z-signal
	34	Home in positive direction, Homing point = motor Z-signal
	35-37	Set current position as homing point

Index 6099h-01	Label	High speed homing			Unit	Command unit/s	Structure	VAR	Type	UInt 32
	Access	R W	Mapping	RPDO	Mode	P/V/T	Range	0~214 74836 47	Default	10000
To set the speed used in homing										

Index 6099h-02	Label	Low speed homing			Unit	Command unit/s	Structure	VAR	Type	UInt 32
	Access	R W	Mapping	RPDO	Mode	P/V/T	Range	0~214 74836 47	Default	5000
To set the speed used in homing										

Index 609Ah	Label	Homing acceleration /deceleration			Unit	Command unit/s ²	Structure	VAR	Type	UInt 32
	Access	R 0	Mapping	TPDO	Mode	P/V/T	Range	1~214 74836 47	Default	500000
To set acceleration and deceleration used in homing										

Index 60B0h	Label	Position feedforward			Unit	Command unit	Structure	VAR	Type	Int 32
	Access	R 0	Mapping	TPDO	Mode	P/V/T	Range	- 2147483647~2 147483647	Default	0

To add position deviation to target position

Index 60B1h	Label	Velocity feedforward			Unit	Command unit/s	Structure	VAR	Type	Int 32
	Access	R 0	Mapping	TPDO	Mode	P/V	Range	- 2147483647~2 147483647	Default	0

To deviate velocity command

Index 60B2h	Label	Torque feedforward			Unit	0.1%	Structure	VAR	Type	Int 16
	Access	R W	Mapping	RPDO	Mode	P/V	Range	0x0~0xFFFF	Default	0x0
To add or deviate torque command										

Index 60B8h	Label	Probe function			Unit	-	Structure	VAR	Type	UInt 16
	Access	RW	Mapping	RPDO	Mode	P/V /T	Range	0x0- 0xFFFF	Default	0x0
	Bit	Description			Details					
	0	Probe 1			0--Disable 1--Enable					
	1	Probe 1 trigger mode			0--Single trigger, triggered only when trigger signal is valid 1--Continuous trigger					
	2	Probe 1 trigger signal selection			0--Probe 1 captured 1--Z signal					
	3	Reserved			-					
	4	Probe 1 rising edge enabled			0--Disable 1--Enable					
	5	Probe 1 falling edge enabled			0--Disable 1--Enable					
	6-7	Reserved			-					
	8	Probe 2			0--Disable 1--Enable					
	9	Probe 2 trigger mode			0--Single trigger, triggered only when trigger signal is valid 1--Continuous trigger					
	10	Probe 2 trigger signal selection			0--Probe 2 captured 1--Z signal					
	11	Reserved			-					
	12	Probe 2 rising edge enabled			0--Rising edge not latched 1--Rising edge latched					
	13	Probe 2 falling edge enabled			0--Falling edge not latched 1--Falling edge latched					
	14-15	Reserved			-					

Index 60B9h	Label	Probe status			Unit	-	Structure	VAR	Type	UInt 16																																	
	Access	R0	Mapping	TPDO	Mode	P/V/ T	Range	00x- 0xFFFF	Default	0x0																																	
<table border="1"> <thead> <tr> <th>Bit</th> <th>Definition</th> <th>Details</th> </tr> </thead> <tbody> <tr> <td>0</td> <td>Probe 1</td> <td>0--Disable 1--Enable</td> </tr> <tr> <td>1</td> <td>Probe 1 rising edge latching</td> <td>0--Rising edge not latched 1--Rising edge latched</td> </tr> <tr> <td>2</td> <td>Probe 1 falling edge latching</td> <td>0--Falling edge not latched 1--Falling edge latched</td> </tr> <tr> <td>3-5</td> <td>-</td> <td>-</td> </tr> <tr> <td>6-7</td> <td>-</td> <td>-</td> </tr> <tr> <td>8</td> <td>Probe 2</td> <td>0--Disable 1--Enable</td> </tr> <tr> <td>9</td> <td>Probe 2 rising edge latching</td> <td>0--Rising edge not latched 1--Rising edge latched</td> </tr> <tr> <td>10</td> <td>Probe 2 falling edge latching</td> <td>0--Falling edge not latched 1--Falling edge latched</td> </tr> <tr> <td>11-13</td> <td>-</td> <td>-</td> </tr> <tr> <td>14-15</td> <td>-</td> <td>-</td> </tr> </tbody> </table>											Bit	Definition	Details	0	Probe 1	0--Disable 1--Enable	1	Probe 1 rising edge latching	0--Rising edge not latched 1--Rising edge latched	2	Probe 1 falling edge latching	0--Falling edge not latched 1--Falling edge latched	3-5	-	-	6-7	-	-	8	Probe 2	0--Disable 1--Enable	9	Probe 2 rising edge latching	0--Rising edge not latched 1--Rising edge latched	10	Probe 2 falling edge latching	0--Falling edge not latched 1--Falling edge latched	11-13	-	-	14-15	-	-
Bit	Definition	Details																																									
0	Probe 1	0--Disable 1--Enable																																									
1	Probe 1 rising edge latching	0--Rising edge not latched 1--Rising edge latched																																									
2	Probe 1 falling edge latching	0--Falling edge not latched 1--Falling edge latched																																									
3-5	-	-																																									
6-7	-	-																																									
8	Probe 2	0--Disable 1--Enable																																									
9	Probe 2 rising edge latching	0--Rising edge not latched 1--Rising edge latched																																									
10	Probe 2 falling edge latching	0--Falling edge not latched 1--Falling edge latched																																									
11-13	-	-																																									
14-15	-	-																																									

Index 60BAh	Label	Probe 1 rising edge captured position			Unit	Command unit	Structure	VAR	Type	Int 32
	Access	R0	Mapping	TPDO	Mode	P/V/T	Range	- 2147483647 ~214748364 7	Default	0
Shows position feedback at rising edge of probe 1 signal										
Index 60BBh	Label	Probe 1 falling edge captured position			Unit	Command unit	Structure	VAR	Type	Int 32
	Access	R0	Mapping	TPDO	Mode	P/V/T	Range	- 2147483647 ~214748364 7	Default	0
Shows position feedback at falling edge of probe 1 signal										
Index 60BCh	Label	Probe 2 rising edge captured position			Unit	Command unit	Structure	VAR	Type	Int 32
	Access	R0	Mapping	TPDO	Mode	P/V/T	Range	- 2147483647 ~214748364 7	Default	0
Shows position feedback at rising edge of probe 2 signal										

Index 60BDh	Label	Probe 2 falling edge captured position			Unit	Command unit	Structure	VAR	Type	Int 32
	Access	R0	Mapping	TPDO	Mode	P/V/T	Range	- 2147483 647~214 7483647	Default	0
Shows position feedback at falling edge of probe 2 signal										

Index 60C5h	Label	Protocol maximum acceleration			Unit	Command unit/s ²	Structure	VAR	Type	UInt 32
	Access	R W	Mapping	RPDO	Mode	P/V/T	Range	1~2147483 647	Default	100000 000
To set upper limit of acceleration.										

Index 60C6h	Label	Protocol maximum deceleration			Unit	Command unit/s ²	Structure	VAR	Type	UInt 32
	Access	R W	Mapping	RPDO	Mode	P/V/T	Range	1~2147483 647	Default	100000 000
To set lower limit of acceleration.										

Index 60D5h	Label	Probe 1 rising edge captured count(s)			Unit	-	Structure	VAR	Type	UInt 16
	Access	R0	Mapping	TPDO	Mode	P/ V/T	Range	0~65535	Default	0
Shows the number of times probe 1 rising edge latched.										

Index 60D6h	Label	Probe 1 falling edge captured count(s)			Unit	-	Structure	VAR	Type	UInt 16
	Access	R0	Mapping	TPDO	Mode	P/ V/T	Range	0~65535	Default	0
Shows the number of times probe 1 falling edge latched.										

Index 60D7h	Label	Probe 2 rising edge captured count(s)			Unit	-	Structure	VAR	Type	UInt 16
	Access	R0	Mapping	TPDO	Mode	P/ V/T	Range	0~65535	Default	0
Shows the number of times probe 2 rising edge latched.										

Index 60D8h	Label	Probe 2 falling edge captured count(s)			Unit	-	Structure	VAR	Type	UInt 16
	Access	R0	Mapping	TPDO	Mode	P/V/T	Range	0~65535	Default	0
Shows the number of times probe 2 falling edge latched.										

Index 60E0h	Label	Max. torque in positive direction			Unit	0.1%	Structure	VAR	Type	UInt 16
	Access	R W	Mapping	RPDO	Mode	P/V/T	Range	0~65535	Default	3000
To set the maximum torque of servo driver in positive direction										

Index 60E1h	Label	Max. torque in negative direction			Unit	0.1%	Structure	VAR	Type	UInt 16
	Access	R W	Mapping	RPDO	Mode	P/V/T	Range	0~65535	Default	3000
To set the maximum torque of servo driver in negative direction										

Index 60F4h	Label	Actual following error			Unit	Command unit	Structure	VAR	Type	Int 32
	Access	R0	Mapping	TPDO	Mode	P	Range	- 214748364 7~2147483 647	Default	0
Shows position following error										

Index 60FAh	Label	Position loop velocity output			Unit	Command unit/s	Structure	VAR	Type	Int 32
	Access	R0	Mapping	TPDO	Mode	P	Range	- 21474836 47~21474 83647	Default	0
Shows internal command velocity (Position loop output)										

Index 60FCh	Label	Internal command position			Unit	Encoder unit	Structure	VAR	Type	Int 32
	Access	R0	Mapping	TPDO	Mode	P	Range	- 214748364 7~2147483 647	Default	0
Shows internal command position of servo driver.										

Index 60FDh	Label	Input status			Unit	-	Structure	VAR	Type	UINT 32
	Access	R0	Mapping	TPDO	Mode	P	Range	- 214748364 8~2147483 647	Default	0

The bits of 60FDh object are functionally defined as follow:

Bit31	Bit30	Bit29	Bit28	Bit27	Bit26	Bit25	Bit24
Z signal	Reserved	Reserved	Reserved	Probe 2	Probe 1	BRAKE	INP/V-COIN/TLC
Bit23	Bit22	Bit21	Bit20	Bit19	Bit18	Bit17	Bit16
E-STOP	Reserved	Reserved	Reserved	Reserved	Reserved	DI14	DI13
Bit15	Bit14	Bit13	Bit12	Bit11	Bit10	Bit9	Bit8
DI12	DI11	DI10	DI9	DI8	DI7	DI6	DI5
Bit7	Bit6	Bit5	Bit4	Bit3	Bit2	Bit1	Bit0
DI4	DI3	DI2	DI1	Reserved	HOME	POT	NOT

Index 60FEh-01	Label	Output valid			Unit	-	Structure	VAR	Type	UInt 32
	Access	RW	Mapping	RPDO	Mode	P/V/T	Range	0x0~0x7FFF FFFF	Default	0x0

The bits of 60FEh object are functionally defined as follow:

Bit Sub-index	31~21	21	20	19	18	17	16	15~0
01h	-	D06 valid	D05 valid	D04 valid	D03 valid	D02 valid	D01 valid	-

Index 60FEh-02	Label	Output enabled			Unit	-	Structure	VAR	Type	UInt 32
	Access	R W	Mapping	RPDO	Mode	P/V /T	Range	0x0~0x7FFFFFFF FF	Default	0xFFFFF0 000

The bits of a 60FEh object are functionally defined as follow:

Bit Sub-index	31~21	21	20	19	18	17	16	15~0
02h	Reserved	D06 enabled	D05 enabled	D04 enabled	D03 enabled	D02 enabled	D01 enabled	Reserved

Index 60FFh	Label	Target velocity			Unit	Command unit	Structure	VAR	Type	Int 32
	Access	R W	Mapping	RPDO	Mode	V	Range	- 2147483647~ 2147483647	Default	0

Shows set target velocity. Limited by 6080h

Index 6502h	Label	Supported operation modes			Unit	-	Structure	VAR	Type	UInt 32
	Access	R0	Mapping	TPDO	Mode	P/V/T	Range	0x0~0x7FFF FFFF	Default	0x0

Shows the control modes supported by the servo drive.